

**Frequency
Inverter**

**FR-S 500
EC/ECR**

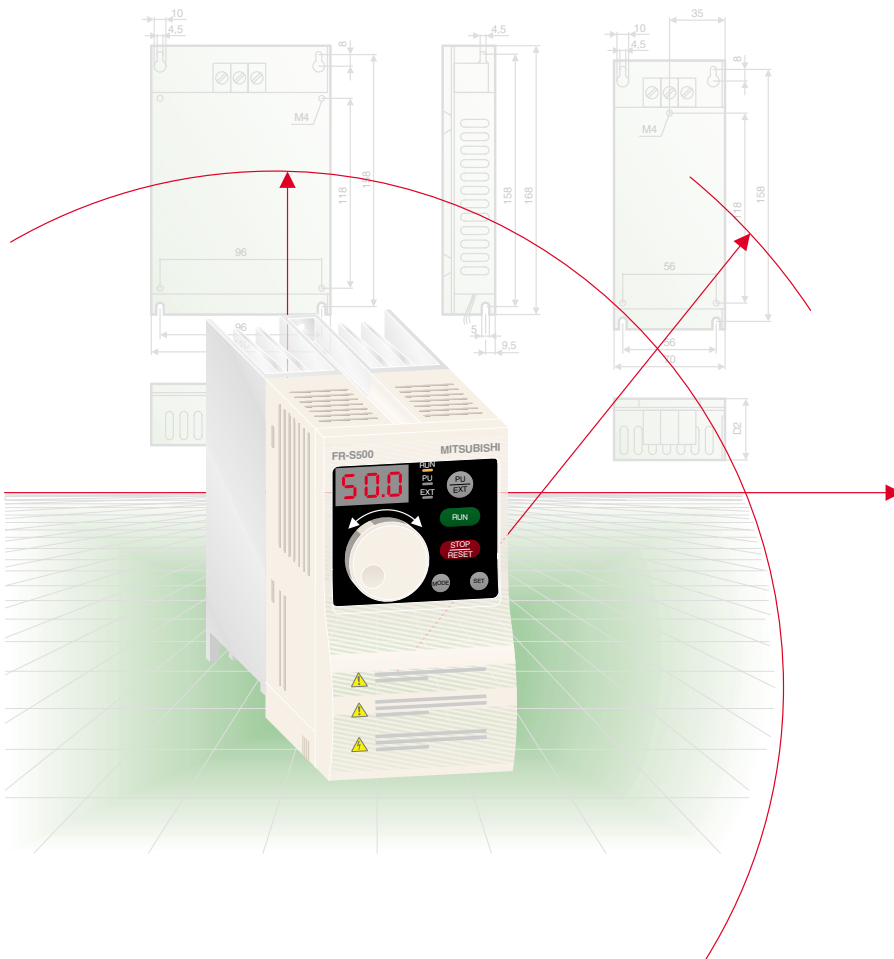

Technical Catalogue

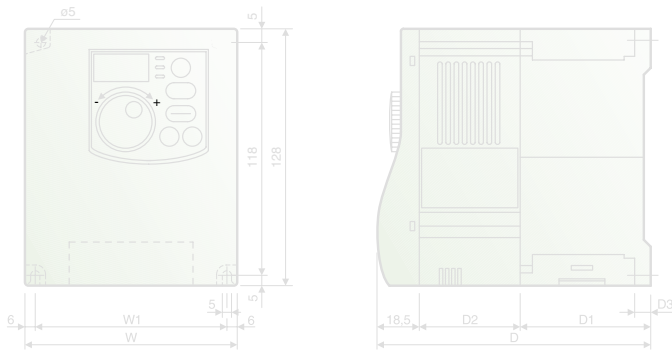

FR-S 500 EC Frequency Inverters

**Dial in Your
Advantage**

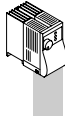

The inverters are available in the performance range from 0.2 to 1.5 kW for operation with single-phase 200 to 240 V AC power supplies (50/60 Hz) and for capacities of 0.4 kW to 3.7 kW with three-phase 380 to 480 V AC power supplies (50/60 Hz).

Further Publications within the Factory Automation Range

**Technical
Catalogues**

Technical catalogues FR-A 500, FR-F 500 and FR-S 500

Product catalogues for frequency inverters and accessories of the FR-A 500 (L-G) EC, FR-F 500L and FR-S 500 series

Technical catalogues MELSERVO and Motion Controllers

Product catalogues for MR-J2S series amplifiers, servo motors and motion controllers with SSCNET connection

Technical catalogues PLC and HMI

Product catalogues for programmable logic controllers, operator terminals, software, and accessories of the MELSEC PLC series

Technical catalogue Networks

Product catalogue for Master and Slave modules as well as accessories for the use of programmable logic controllers and frequency inverters in open and MELSEC networks (art. no. 136730)

Additional services

You will find current information on updates, alterations, new items, and technical support on MITSUBISHI ELECTRIC's web pages (www.mitsubishi-automation.com).

The products section of the MITSUBISHI home site includes various documentations of the whole product range by MITSUBISHI ELECTRIC as well as the current version of this catalogue on hand. All manuals and catalogues can be downloaded.

The content is updated daily and to date is provided in German and English.

About this product catalogue

This catalogue is periodically updated due to product range enlargement, technical changes or new or changed features.

Texts, figures and diagrams shown in this product catalogue are intended exclusively for explanation and assistance in planning and ordering the frequency inverter series FR-S 500 EC/ECR and the associated accessories. Only the manuals supplied with the devices are relevant for installation, commissioning and handling of the devices and the accessories. The information given in these manuals must be read before installation and commissioning of the devices or software.

Should questions arise with regard to the planning of devices described in this product catalogue, do not hesitate to contact MITSUBISHI ELECTRIC EUROPE B.V. in Ratingen (Germany) or one of its distributors (see cover page).

© MITSUBISHI ELECTRIC EUROPE B.V. 01/2004 (5th edition - version E)

FREQUENCY INVERTER FR-S 500 EC/ECR

SYSTEM DESCRIPTION

- ◆ Introduction of the FR-S series 4
- ◆ Equipment and configuration 5
- ◆ The integrated control panel 6
- ◆ Specifications 8
- ◆ Terminal assignment 10
- ◆ Optional parameter unit FR-PU04 12



PARAMETERS + PROTECTIVE FUNCTIONS

- ◆ Overview of parameters 14
- ◆ Overview of protective functions 17
- ◆ Activating a protective function and resetting methods 18
- ◆ Sample applications 19



ACCESSORIES

- ◆ Overview of options 20
- ◆ Noise filters 21
- ◆ Brake units 21



DIMENSIONS

- ◆ Parameter unit 22
- ◆ Frequency inverters 23
- ◆ Noise filters 24
- ◆ Brake units 25



APPENDIX

- ◆ Order form 26
- ◆ Index 27

The Frequency Inverter FR-S 500 EC/ECR

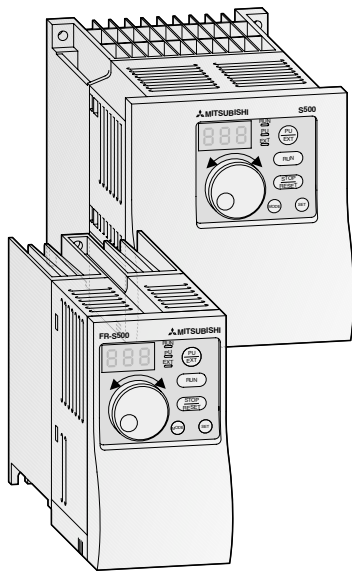

With the FR-S 500 EC/ECR, newly developed by MITSUBISHI ELECTRIC a frequency inverter is at your service that – due to its versatility and compact dimensions – solves your individual drive tasks efficiently.

The ultra-compact frequency inverters FR-S 500 EC/ECR allow for numerous applications. Typical applications include for example:

- Material transport systems such as conveyor belts, chain conveyors, feed belts, transport belts and worm conveyors
- Saws, milling cutters, grinding and drilling machines
- Pumps
- Fans
- Door drives

The frequency inverters are available with outputs from 0.2 to 1.5 kW for operation with single-phase 200 to 240 V AC power supply (FR-S 520 S EC/ECR) or 0.4 to 3.7 kW with three-phase 380 to 480 V AC power supply (FR-S 540 EC/ECR).

The frequency range is from 0.5 to 120 Hz.

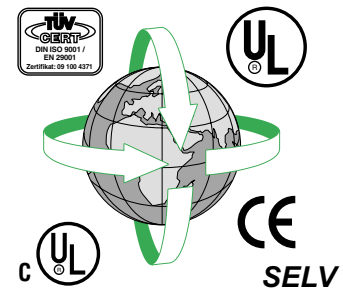

Overview of the Outstanding Characteristics

Communications capability and networking

In the FR-S 500 ECR the comprehensive functions of the EC series are complemented by a serial interface (RS485) installed as standard equipment. This enables communication both with a personal computer and with a PLC, which can be networked with up to 31 other devices with RS485 interface.

Compatible with many new applications

- PID control
The integrated PID control for example supports a flow control for pumps.
- Torque boost
Automatic torque boost selection is possible.

Comprehensive protection functions for safe operation

- Built-in electronic overcurrent protection
- Free selection of the protection function for automatic retry after alarm occurrence.

Compatible with numerous I/Os

- Multi-speed operation
15 different pre-selected speeds are available
- Control input for 0/4–20 mA (0–10 V)
- 4 Multi-input terminals
Selection of different input variations from 14 different input types (e. g. digital motor potentiometer)
- Multi-output terminals
Selection of 2 different output variations from 12 different output types
- 24-V power supply output (24 V DC/0.1 A) for external devices
- Analog output from 0 to 5 V

Automatic torque boost

The new transistorized power module supports an automatic torque boost on demand feature for significantly more stable drive performance.

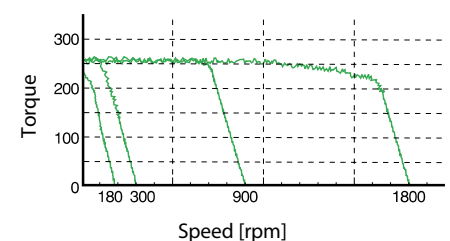

User-friendly Operation

Easy operation

The **integrated control panel** provides a quick and easy operation of the frequency inverter and displays several operational signals and error messages. The "Digital Dial" provides a far more quick and direct access to all important drive parameters than conventional keys would allow.

In addition, for example the speed of the connected motor can be continuously controlled directly.

For a remote control of the inverter among others the parameter unit **FR-PU04** is available. It provides a long-life backlight LC display. Operational data is input directly via the numeric keypad.

Eight different selectable languages are supported by the display.

The integrated copy function transfers the entire parameter settings to other inverters and thus shortens the initialisation time significantly.

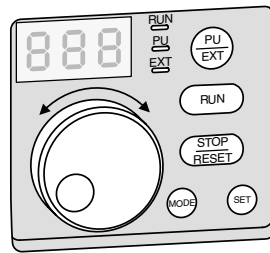

Integrated control panel

In addition to control panel operation the frequency inverter can also be connected to a standard PC via an RS-485 port and operated from the PC with the optional VFD setup software package (see page 20). Version 2.4 and above of this package run under Windows® 95, 98, Me and XP and also under Windows® NT and 2000. Using this software you can configure, operate and monitor multiple frequency inverters in a network or directly from a single PC or notebook computer.

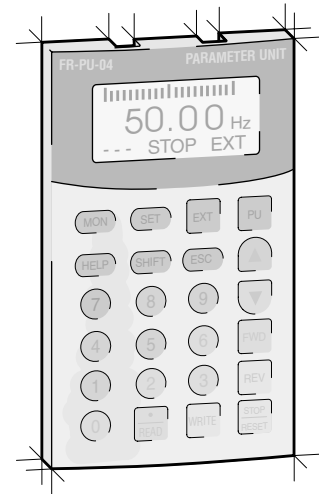

FR-PU04

By default, only the 12 most important parameters are activated to ensure a quick parameterizing. If required, all parameters can be easily accessed.

Simplified Maintenance

Easy access to cooling fans

The easily accessible cooling fans can be replaced quickly and easily, if required.

The integrated cooling fan can be switched OFF automatically in stand-by operation to increase its lifetime significantly.

Easy installation and maintenance

Since the control and power terminal block is easy of access, the installation and maintenance of the inverter is also very easy.

All connection points are designed as screw terminals.

The housing includes a cable routing facility which can be removed for installing.

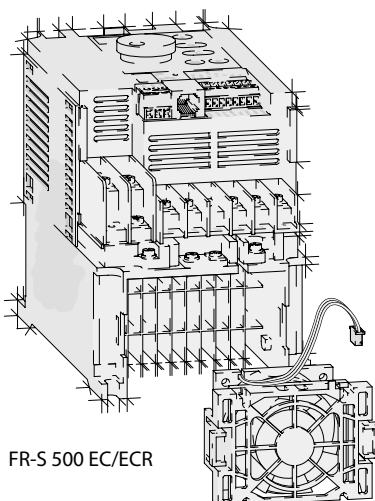

FR-S 500 EC/ECR

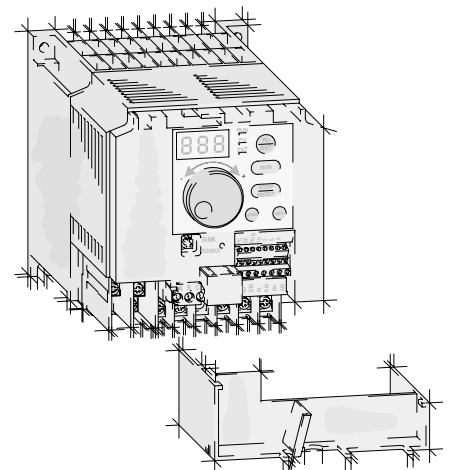
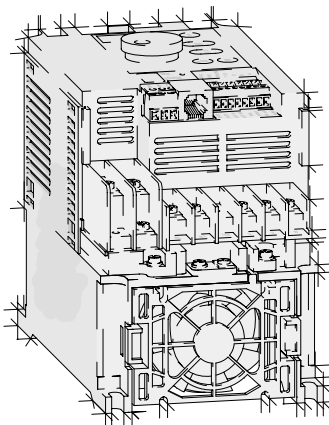

The Integrated Control Panel

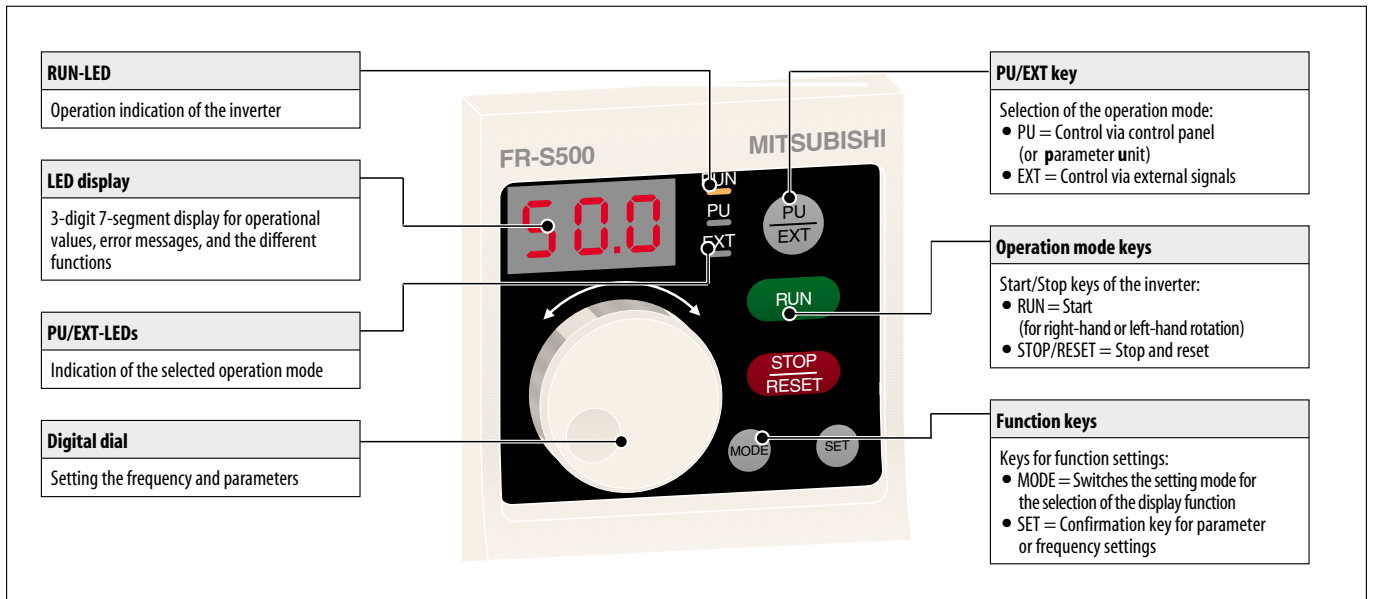

Menu Guide

The control panel facilitates the setting and display of different control variables (parameters) and the monitoring and output of current operational values and alarm messages. All the information is output on a 3-digit LED display.

Besides the display and setting of the parameters all operation conditions of inverter and motor can be monitored. Malfunction is indicated by error codes.

Fast, simple configuration and operation save time and money. The integrated "digital dial" jog shuttle control gives the user direct and much faster access to all key drive parameters than is possible with standard pushbutton solutions.

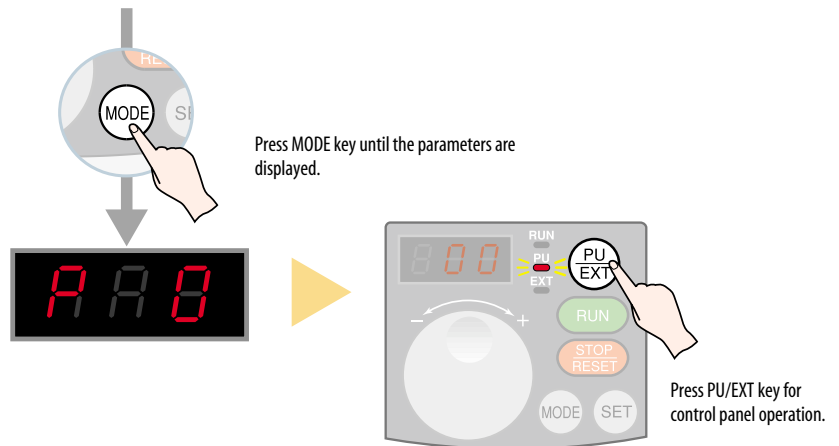

Parameter Setting Procedure

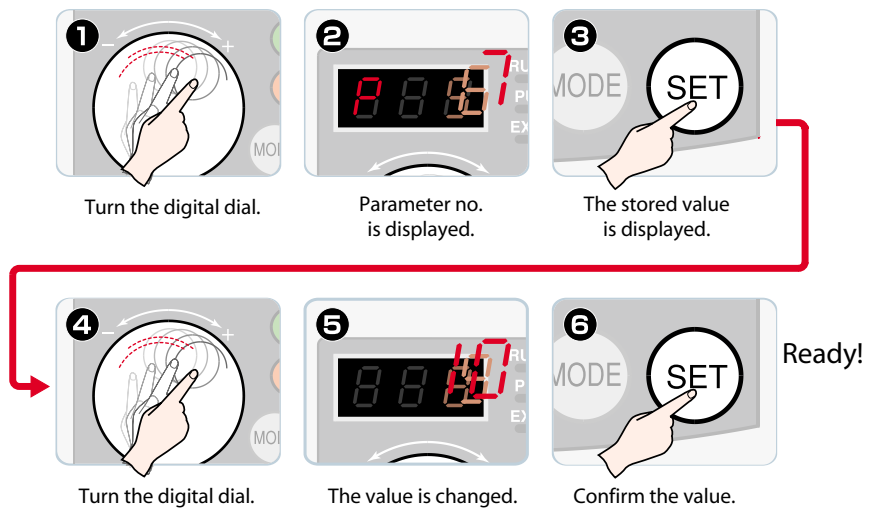

Environmentally Friendly Operation

Soft-PWM control

In addition to the conventional low-noise mode, MITSUBISHI ELECTRIC has developed its original Soft-PWM control that suppresses acoustic noise and limits RFI noise to a minimum.

The switchable PWM control facilitates a motor noise as silent as whisper even at low carrier frequencies. The diagrams illustrate the difference.

In the upper diagram the frequency components are dispersed: The inverter only generates little noise that might be compared to the sound of flowing water.

The noise does not sound unpleasant.

In the lower diagram the frequency components are concentrated: The inverter generates the typical noise.

With Soft-PWM control

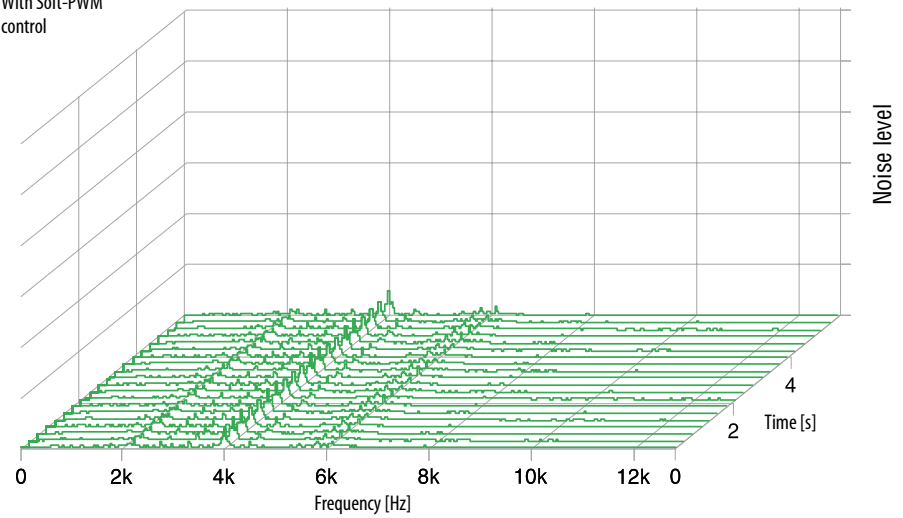

Without Soft-PWM control

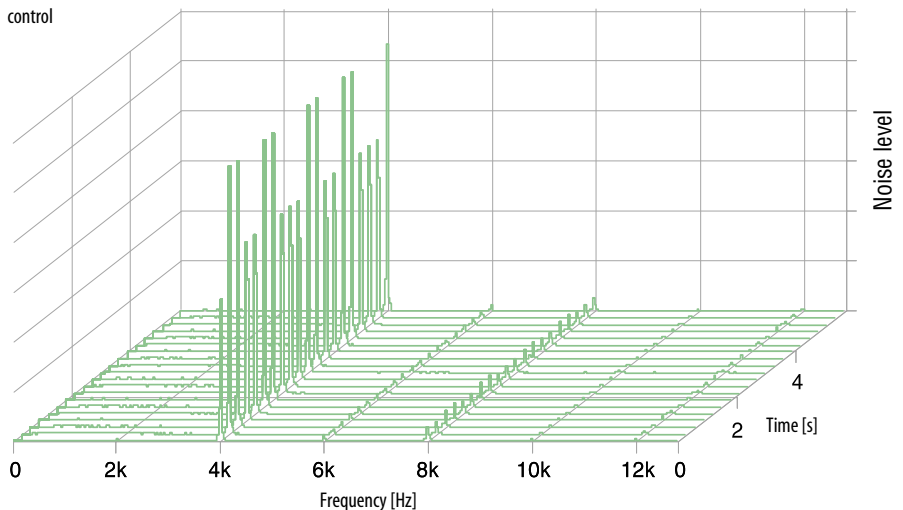

EMC compatibility

Regarding its electromagnetic compatibility the frequency inverter FR-S 500 EC/ECR complies with the European EMC directives. To meet these standards specially adjusted compact noise filters have been developed for each performance range. These noise filters can be mounted simply on or under the inverter.

For details refer to page 21.

By connecting an optional converter choke coil harmonic feedback into the mains supply is suppressed.

Standards

The devices of the FR-S 500 EC/ECR product line are designed to be used world-wide without further effort or certifications.

- Compliant with world-wide standards CE, UL, cUL
- Selectable sink or source logic
The logic for input and output signals can be freely selected. The result is a flexible and easy customization of the units to the needs of the world market.
- Extended input voltage range
FR-S 520 EC/ECR: 1~ 200–240 V; 50/60 Hz;
FR-S 540 EC/ECR: 3~ 380–480 V; 50/60 Hz;
Tolerance: –15 %; +10 %
- Multi-language parameter unit (8 languages) optionally available

- Due to the integrated PID control the frequency inverter for instance can be used for temperature control without further requirements.
- All inverters are equipped with an in-rush current limiter protecting the connected components.
- MS-Windows compatible world-wide standardized multi-language parameterizing software (VFD-Setup).

The FR-S 500 EC/ECR is a world product complying with all relevant standards and easily adopting to the according needs of a country.

Specifications FR-S 500 EC/ECR

Product line		FR-S 520 S EC/ECR				FR-S 540 EC/ECR							
		-0.2 k	-0.4 k	-0.75 k	-1.5 k	-0.4 k	-0.75 k	-1.5 k	-2.2 k	-3.7 k			
Output	Applicable motor capacity* ^①	kW	0.2	0.4	0.75	1.5	0.4	0.75	1.5	2.2	3.7		
	Rated motor capacity	kVA	0.5	1.0	1.6	2.8	0.9	1.6	2.7	3.7	5.9		
	Rated current*	A	1.4	2.5	4.1	7.0	1.2 (1.3)*	2.3 (2.5)*	3.7 (4.1)*	5.3 (5.8)*	7.7 (8.5)*		
	*Overload capacity ^②	200 % of rated motor capacity for 0.5 s; 150 % for 1 min. (ambient temperature not higher than 50 °C)											
	Voltage ^③	3phase, 0 V up to power supply voltage											
Input	Power supply voltage	1phase, 200–240 V AC, –15 % / +10 %					3phase, 380–480 V AC, –15 % / +10 %						
	Voltage range	170–264 V AC at 50 / 60 Hz					325–528 V AC at 50 / 60 Hz						
	Frequency range	50 / 60 Hz ± 5 %					50 / 60 Hz ± 5 %						
	Rated input capacity ^④	kVA	0.9	1.5	2.5	4.4	1.5	2.5	4.5	5.5	9.5		
Control specifications	Control method	V/f control or automatic torque boost control											
	Modulation method	Sinusoidal PWM, Soft PW											
	PWM switching frequency	kHz	0.7–14.5, user adjustable										
	Frequency range	Hz	0.5–120										
	Frequency resolution	Analog	From terminals 2-5: 1/500 of maximum set frequency (input 5 V DC); 1/1000 (input 10 V, 20 mA DC)										
		Digital	0.01 Hz / 50 Hz (pulse input included)										
	Frequency precision	±1 % of max. output frequency (temperature range 25 °C±10 °C) during analog input; ±0.5 % of max. output frequency during digital input (set via Digital Dial)											
	Voltage / frequency characteristics	Base frequency adjustable from 0 to 120 Hz											
	Possible starting torque	≥ 150 % / 6 Hz (with automatic torque boost)											
	Torque boost	Manual torque boost; selectable between 0–30 %											
	Acceleration / deceleration time	0, 0.1 to 999s (may be set individually for acceleration and deceleration)											
	Acceleration / deceleration characteristics	Linear or S-pattern acceleration/deceleration mode selectable											
	Braking torque ^⑤	Regenerative	0.2 k: 150 %; 0.4 k and 0.75 k: 100 %; 1.5 k: 50 %; 2.2 k and 3.7 k: 20 %										
		DC braking	Braking time and braking moment adjustable, Operating frequency: 0–120 Hz, operating time: 0–10 s, voltage: 0–15 % (externally adjustable)										
	Current stall prevention operation level	Operation current level setting 0–200 %, user adjustable											
High-response current restriction level	Operation level is fixed, enable/disable selection												
Motor protection	Electronic motor protection relay (rated current user adjustable)												
Control signals for operation	Frequency setting signal	Analog input	0–5 V DC, 0–10 V DC, 0/4–20 mA										
		Digital input	From control panel (parameter unit), RS-485 or network										
	Input signals	Start signal	Individual selection of forward / reverse run Start signal self retaining input										
		Multi-speed selection	Up to 15 speeds can be preset in the range of 0–120 Hz. The current speed can be adjusted during operation via the control panel.										
		2nd function	Selects 2nd function (acceleration time, deceleration time, torque boost, base frequency, electronic overcurrent protection)										
		Selection of current input	Frequency setting via current input signal 0/4 to 20 mA DC (terminal 4)										
		External thermal input	Stopping the inverter with an externally mounted thermal relay										
		PU<->External operation	Switch between the operating modes "PU" and "External"										
		PID control	Select PID control										
		Output stop	Instant cutoff of inverter output (frequency and voltage)										
	Alarm reset	The error indication (alarm signal) is reset with the reset of the protective function.											
	Operation functions	Maximum and minimum frequency setting, frequency jump operation, external thermal input selection, instantaneous power failure restart operation, forward run/reverse run prevention, slip compensation, operation mode selection, PID control, computer link or open network operation (FR-S 500 ECR with RS485 interface only)											
	Output signals	Operation status	1 output type (open collector output) selectable: Inverter running, frequency reached, frequency detection, overload warning, zero return detection, output current detection, maximum PID, minimum PID, PID forward run, PID reverse run, operation ready, minor failure and error. Instead of the open collector output type 1 relay contact can be selected for the output (230 V AC; 0.3 A / 30 V DC; 0.3 A).										
		Analog signal	One of the following output types can be selected: Output frequency, motor current, analog output (0–5 V DC with 1 mA full scale).										

* The values in brackets indicate the values for an ambient temperature up to 40 °C without restriction of PWM.

Product line			FR-S 520 S EC/ECR				FR-S 540 EC/ECR			
			-0.2 k	-0.4k	-0.75 k	-1.5 k	-0.4 k	-0.75 k	-1.5 k	-2.2 k
Display option	Displayed on integrated control panel	Operating state	Output voltage, motor current, frequency setting value, operation speed							
		Alarm display	Error messages are displayed after a protective function has been activated. Up to 4 error codes can be stored.							
	Additional displays on parameter unit FR-PU04	Operating state	Signal status of input and output terminals							
		Interactive operating guide	Interactive guide for operation and troubleshooting via help function							
Protection	Functions	Overcurrent cutoff (during acceleration, deceleration, constant speed), regenerative overvoltage cutoff (during acceleration, deceleration, constant speed), overload cutoff (motor/inverter), fan overheating, fan error ^⑦ , overcurrent cut off, ground fault during start ^⑧ , external motor protection signal ^⑨ , PU connection error ^⑩ , number of retries, communications error ^⑩ , CPU error, overvoltage ^⑩								
	Protective structure	IP 20								
Others	Cooling	Self-cooling	Self-cooling	Self-cooling	Fan cooling	Self-cooling	Self-cooling	Fan cooling	Fan cooling	Fan cooling
	Stray power (W)	20	45	50	85	40	50	80	110	170
	Weight (kg)	0.6	0.8	1.0	1.5	1.5	1.5	1.5	1.6	1.7

Remarks:

- ① The specifications of the rated motor capacity are related to a motor voltage of 230 V for 1phase output and 400 V for 3phase output (max. ambient temperature of 50 °C).
- ② The overload capacity indicated in % is the ratio of the overload current to the inverters rated current. For repeated duty, allow time for the inverter and motor to return to or below the temperature and 100 % load.
- ③ The maximum output voltage cannot exceed the input voltage. The maximum output voltage may be programmed individually, but it must be input voltage.
- ④ The input capacity changes with the values of the power supply side inverter impedances (including those of the input reactor and cables).
- ⑤ The braking torque indicated is short-duration average torque (which varies with motor loss) when the motor alone is decelerated from 50 Hz in the shortest time and is not a continuous regenerative torque. When the motor is decelerated from the frequency higher than the base frequency, the average deceleration torque will reduce. Since the inverter does not contain a brake resistor, use the optional brake resistor when regenerative energy is large. A brake unit (e.G. BU-UFS) may also be used.
- ⑥ Only valid for frequency inverters equipped with an RS485 interface.
- ⑦ Only valid for frequency inverters equipped with a cooling fan.
- ⑧ To activate the function, set parameter 40 to "1".
- ⑨ The input OH is activated by the parameters on the function assignment of the input terminals (Pr. 60 to Pr. 63).
- ⑩ When undervoltage or instantaneous power failure has occurred, alarm display or alarm output is not provided but the inverter itself is protected. Overcurrent, regenerative overvoltage, or other protection may be activated at power restoration according to the operating condition.

Product line			FR-S 520 S EC/ECR				FR-S 540 EC/ECR			
			-0.2 k	-0.4k	-0.75 k	-1.5 k	-0.4 k	-0.75 k	-1.5 k	-2.2 k
EC	Art. no.	129299	129300	129301	129342	136087	136088	136089	136090	136091
ECR		129343	129344	129345	129346	136102	136103	136104	136105	136106

General Operating Conditions

Item	Specifications
Ambient temperature in operation	-10 °C bis +50 °C (non-freezing)
Storage temperature	-20 to +65 °C
Ambient humidity	Max. 90 % (non-condensing)
Altitude	Max. 1000 m above sea level
Protective structure	Enclosed type IP 20
Shock resistance	10 G (3 times each in 3 directions)
Vibration resistance	0.6 G: resistance to vibrations from 10 to 55 Hz for 2 hours along all 3 axes
Ambient conditions	For indoor use only, avoid environments containing corrosive gases, install in a dust-free location.
Approvals	UL / CSA / CE / EN

Block Diagram (Source Logic)

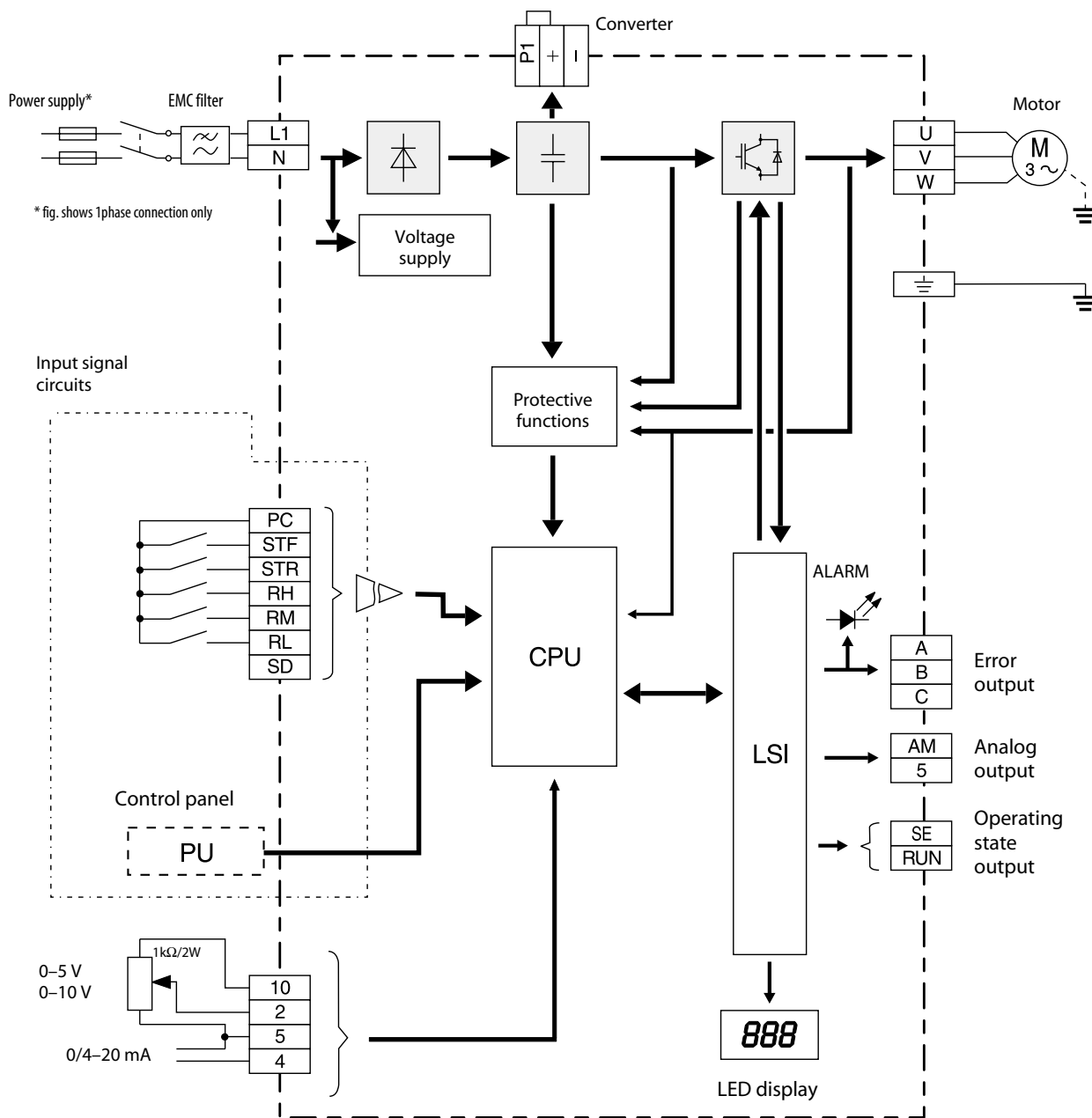

Terminal Assignment of Main Circuit Terminals

Function	Terminal	Terminal name	Description
Main circuit connection	L1, N	Power supply 1phase	Power supply of the inverter types FR-S 520 S EC/ECR (200–240 V AC, 50/60 Hz)
	L1, L2, L3, N	Power supply 3phase	Power supply of the inverter types FR-S 540 EC/ECR (380–480 V AC, 50/60 Hz)
	+, -	External brake unit connection	An external brake unit can be connected to the terminals + and -.
	P1, +	Converter choke coil connection	An optional choke coil can be connected to the terminals P1 and +. Before connecting the choke coil, disconnect the jumper from terminals P1 and +.
	U, V, W	Motor connection	Voltage output of the inverter (3phase, 0 V up to input voltage, 0.5–120 Hz)
	PE	Protective earth connection of inverter	Protective earth connection of inverter

Terminal Assignment of Signal Terminals

Function	Terminal	Terminal name	Description
Control connection	STF	Forward rotation start	The motor rotates forward, if a signal is applied to terminal STF. If the signals STF and STR are applied simultaneously, the STOP command is executed.
	STR ^①	Reverse rotation start	The motor rotates reverse, if a signal is applied to terminal STR. If the signals STF and STR are applied simultaneously, the STOP command is executed.
	RH, RM, RL ^①	Multi-speed selection	Up to 15 different output frequencies can be preset; for the speed commands the following priorities apply: Jog, speed selection (RH, RM, RL, RX) and AU.
Common	SD ^②	Common sink for contact input/reference potential	A determined control function is activated, if the corresponding terminal is connected to the terminal SD. The SD terminal is isolated from the digital circuits via optocouplers. The terminal is isolated from the terminals 5 and SE.
	PC ^②	+24 V DC output and common source for contact input/reference potential	24 V DC / 0.1 A output via PC-SD In sink logic, when activated by open collector transistors (e.g. PLC) the positive pole of an external power supply has to be connected to the PC terminal. In source logic, the PC terminal serves as common reference point for the control inputs.
Setting value specification	10	Voltage output for potentiometer	Output voltage 5 V DC Max. output current 10 mA Recommended potentiometer: 1 kΩ, 2 W linear (multi-turn potentiometer)
	2	Input for frequency setting value signal	The voltage setting value 0–5 (10) V is applied to this terminal. The voltage range is preset to 0–5 V. The input resistance is 10 kΩ. The maximum permitted voltage is 20 V.
	5	Reference point for frequency setting value signal	Terminal 5 is the reference point for all analog setting values and for the analog output signal AM. The terminal is not isolated from the reference potential of the control circuit and must not be earthed .
	4	Input for current setting value signal 0/4–20 mA DC	The current setting value signal (4–20 mA DC) is applied to this terminal. The input is active only if the AU signal is set. The function of the AU signal is assigned via parameters 60 to 63. The input resistance is 250 Ω., the maximum permitted current is 30 mA. By default, this signal is set to 0 Hz at 4 mA and 50 Hz at 20 mA.
Signal outputs	A, B, C ^③	Potential free alarm output	The alarm is output via relay contacts (C-B = Normally Open, C-A = Normally Closed). The maximum contact load is 230 V AC / 0.3 A or 30 V DC / 0.3 A.
	RUN ^③	Signal output for motor operation	The output is switched low, if the inverter output frequency is equal to or higher than the starting frequency. The output is switched high, if no frequency is output or the DC brake is in operation. The maximum contact load is 24 V DC / 0.1 A.
	SE	Reference potential for signal outputs	Reference potential for the signal RUN. This terminal is isolated from the reference potential of the control circuit 5 and SD.
	AM	Analog output	The output can be used for external frequency output or motor current output. The functions are determined by parameters. A DC voltmeter can be connected. The max. output voltage is 5 V. The maximum permitted output current is 1 mA.
Interface	—	Connection of control panel (RS485) ^④	Communications via RS485 I/O standard: RS485, Multi-drop operation, max. 19200 Baud

Remarks:

- ① The following function assignments are supported: RL, RM, RH, RT, AU, STOP, MRS, OH, REX, JOG, RES, X14, X16, and (STR).
- ② The terminals PC and SD must not be connected to each other nor to the protective earth terminal.
In source logic, the terminal PC serves as common reference point for the control inputs.
In sink logic, the terminal SD serves as common reference point for the control inputs.
- ③ The following function assignments are supported: RUN, SU, OL, FU, RY, Y12, Y13, FDN, FUP, RL, LF, and ABC.
- ④ Only the FR-S 500 ECR series frequency inverters are equipped with an RS485 connector.



Parameter Unit FR-PU04 (Optional)

The parameter unit FR-PU04 including extended functions is available as optional accessory. It provides a 10-key keypad for entering directly numerical values.

A 4-row LC display returns operational data, parameter names, or status and error messages in uncoded text. The parameter unit displays text in the following selectable languages:

English, German, French, Spanish, Swedish, Italian, Finnish, and Japanese.

In addition to the functions of the integrated control panel the FR-PU04 displays and monitors 21 different values and states in total.

In combination with the inverters of the ECR product line only those functions supported by the FR-S500 can be invoked.

For the connection the connecting cable FR-A5 CBL is required.

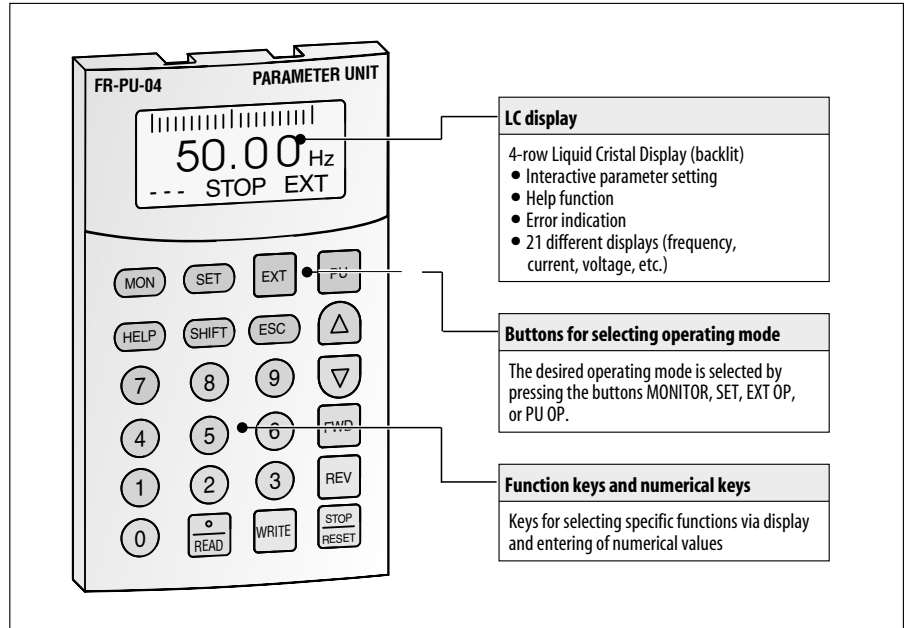

Menu Guide to the Parameter Unit FR-PU04

Displaying parameter lists

Press the SET key to enter the parameter setting menu. Then press the HELP key to display the parameter lists. After pressing the READ key, the according parameter value will be read in.

Copying parameters

Press the SET key and then the ▲ key to enter the copy mode. There are the following three options:

- Press the READ key to read out all parameters from the inverter.
- Press the WRITE key to write parameters to the inverter.
- Press the ▼ key to verify the values stored in the parameter unit and the inverter.

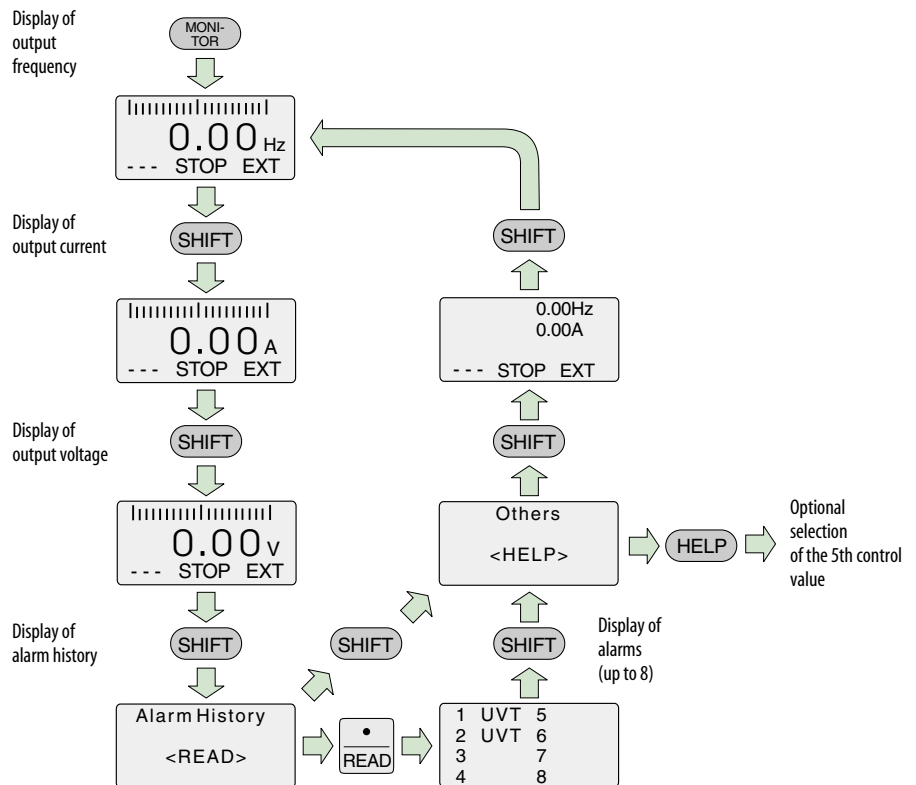

Operating Modes

The inverter can alternatively be operated via external signals or directly via the integrated control panel or an external parameter unit such as FR-PU04. A combined operation is possible too.

The operating mode on the integrated control panel is selected within the operation mode menu. The operating mode on the parameter unit FR-PU04 is selected by pressing the EXT OP key for external signal operation or pressing the PU OP key for parameter unit operation.

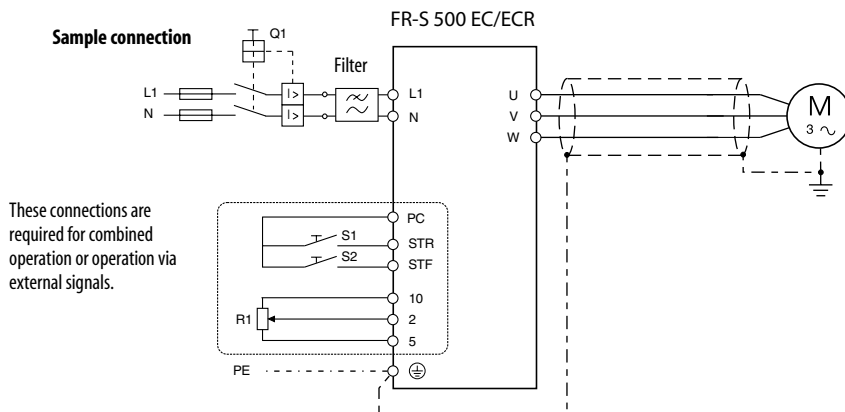

Operation via the integrated control panel

The direction of rotation and frequency setting of the inverter are controlled via the integrated control panel.

The setting of the output frequency is increased or decreased via the "digital dial".

The example below shows the operational steps for a frequency setting including a following motor start and motor stop.

Operation via external signals

The direction of rotation and frequency setting of the inverter are controlled by external signals. The following figure shows the display on the integrated control panel for forward rotation of the motor and a frequency of 50 Hz.

① Press the PU/EXT key.



② Adjust the frequency via the "digital dial".

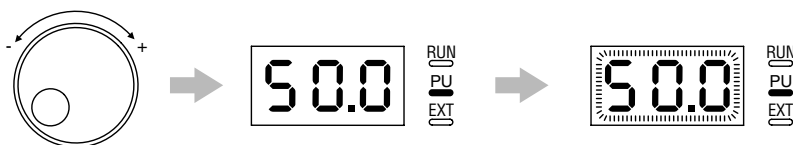

③ Set the frequency via the SET key.

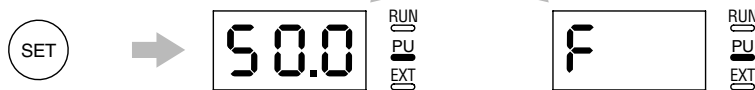

④ Start the motor via the RUN key.

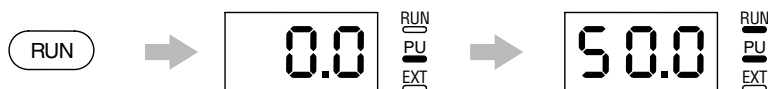

⑤ Stop the motor.

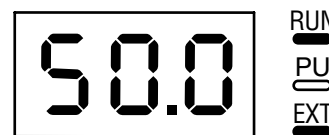
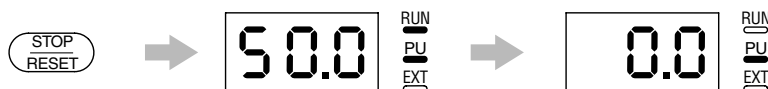

Combined operation

In addition to the operation via external signals and via integrated control panel or external parameter unit the inverter can be operated in combined operation mode.

- Setting value preset via the control panel or parameter unit and external starting signal
- External setting value signal and starting signal via the control panel or parameter unit

Parameters

Function	Parameter	Meaning	Setting range	Default setting
Basic parameters	0	Torque boost (manual)	0 – 15 %	6 % (FR-S 520), 4 %/5 % (FR-S 540)
	1	Maximum output frequency	0 – 120 Hz	60 Hz
	2	Minimum output frequency	0 – 120 Hz	0 Hz
	3	V/f characteristics (base frequency)	0 – 120 Hz	60 Hz
	4	1. Multispeed preset - RH ^①	0 – 120 Hz	60 Hz
	5	2. Multispeed preset - RM ^①	0 – 120 Hz	30 Hz
	6	3. Multispeed preset - RL ^①	0 – 120 Hz	10 Hz
	7	Acceleration time	0 – 999 s	5 s
	8	Deceleration time	0 – 999 s	5 s
	9	Electronic thermal overload relay (motor protection)	0 – 50 A	Rated output current ^③
Parameters for standard drive operation	30	Regenerative function selection ^①	0 / 1 ^①	0
	79	Operating mode selection	0 – 4 / 7 / 8	0
	10	DC injection brake (initial frequency)	0 – 120 Hz	3 Hz
	11	DC injection brake (operation time)	0 – 10 s	0.5 s
	12	DC injection brake (voltage)	0 – 15 %	6 %
	13	Starting frequency	0 – 60 Hz	0.5 Hz
	14	Selection of load pattern	0 – 3	0
	15	JOG frequency	0 – 120 Hz	5 Hz
	16	JOG acceleration and deceleration time	0 – 999 s	0.5 s
	17	RUN key rotation direction selection	0 / 1	0
	19	Max. output voltage	0–500 V (FR-S 520), –800 V (FR-S 540) / 888 / —	888
	20	Acceleration / deceleration reference frequency	1 – 120 Hz	50 Hz
	21	Acceleration / deceleration time increments	0 – 31 / 100	0
	22	Stall prevention operation level ^①	0 – 200 %	150 %
	23	Stall prevention operation at double speed	0 – 200 % / —	—
	24	4. Multispeed preset ^①	0 – 120 Hz / —	—
	25	5. Multispeed preset ^①	0 – 120 Hz / —	—
	26	6. Multispeed preset ^①	0 – 120 Hz / —	—
	27	7. Multispeed preset ^①	0 – 120 Hz / —	—
	28	Stall prevention operation reduction starting frequency	0 – 120 Hz	50 Hz
	29	Acceleration / deceleration pattern	0 / 1 / 2	0
	31	Frequency jump 1A	0 – 120 Hz / —	—
	32	Frequency jump 1B	0 – 120 Hz / —	—
	33	Frequency jump 2A	0 – 120 Hz / —	—
	34	Frequency jump 2B	0 – 120 Hz / —	—
	35	Frequency jump 3A	0 – 120 Hz / —	—
	36	Frequency jump 3B	0 – 120 Hz / —	—
	37	Speed display	0 / 0.1 – 999	0
	38	Frequency at 5 V (10 V) input voltage	1 – 120 Hz	50 Hz
	39	Frequency at 20 mA input current	1 – 120 Hz	50 Hz
40	Ground fault detection	0 / 1	1	
Settings of control outputs	41	Setting value / current value comparison (SU output)	0 – 100 %	10 %
	42	Output frequency monitoring (FU output)	0 – 120 Hz	6 Hz
	43	Output frequency detection for reverse rotation	0 – 120 Hz / —	—
2nd parameter set	44	2. Acceleration / deceleration	0 – 999 s	5 s
	45	2. Deceleration time	0 – 999 s / —	—
	46	2. Manual torque boost	0 – 15 % / —0	—
	47	2. V/f characteristics ^①	0 – 120 Hz / —	—

Function	Parameter	Meaning	Setting range	Default setting
Current detection	48	Output current detection level	0 – 200 %	150 %
	49	Output current detection signal delay time	0 – 10 s	0 s
	50	Zero current detection level	0 – 200 %	5 s
	51	Zero current detection time	0.05 – 1 s	0.5 s
Display functions	52	Control panel display data selection ^①	0 / 1 / 100	0
	53	Digital Dial function selection ^①	0 / 1	0
	54	Output AM terminal ^①	0 / 1	0
	55	Frequency monitoring reference ^①	0 – 120 Hz	50 Hz
	56	External current monitoring reference ^①	0 – 50 A	Rated current
Restart	57	Restart coasting time after power failure	0 – 5 s / —	—
	58	Restart cushion time before automatic synchronisation	0 – 60 s	1 s
Aux. function	59	Selection of digital motor potentiometer	0 / 1 / 2	0
Terminal function selection	60	RL terminal function	0 – 10 / 14 / 16	0
	61	RM terminal function	0 – 10 / 14 / 16	1
	62	RH terminal function	0 – 10 / 14 / 16	2
	63	STR terminal function	0 – 10 / 14 / 16 / —	—
	64	RUN terminal function	0 / 1 / 3 / 4 / 11 – 16 / 98 / 99	0
	65	ABC terminal function	0 / 1 / 3 / 4 / 11 – 16 / 98 / 99	99
Operation selection functions	66	Retry selection	0 / 1 / 2 / 3	0
	67	Number of restart retries	0 – 10 / 101 – 110	0
	68	Waiting time for automatic restart retry	0.1 – 360 s	1 s
	69	Retry count display erasure	0	0
	70	Soft PWM setting ^①	0 / 1	1
	71	Motor selection	0 / 1	0
	72	PWM function ^①	0 – 15	1
	73	Specification of setting value input data	0 / 1	0
	74	Setting value signal filter	0–8	1
	75	Reset selection / PU stop selection ^①	0 / 1 / 14 / 15	14
	76	Cooling fan operation selection	0 / 1	1
	77	Write protection for parameters ^①	0 / 1 / 2	0
	78	Prevention of reverse rotation	0 / 1 / 2	0
Motor constants	80	8. Multispeed preset ^①	0 – 120 Hz / ---	—
	81	9. Multispeed preset ^①	0 – 120 Hz / ---	—
	82	10. Multispeed preset ^①	0 – 120 Hz / ---	—
	83	11. Multispeed preset ^①	0 – 120 Hz / ---	—
	84	12. Multispeed preset ^①	0 – 120 Hz / ---	—
	85	13. Multispeed preset ^①	0 – 120 Hz / ---	—
	86	14. Multispeed preset ^①	0 – 120 Hz / ---	—
	87	15. Multispeed preset ^①	0 – 120 Hz / ---	—
	88	PID action selection	20 / 21	20
	89	PID proportional band ^①	0.1 – 999 % / —	100 %
	90	PID integral time ^①	0.1 – 999 s / —	1 s
	91	PID upper limit	0 – 100 % / —	—
	92	PID lower limit	0 – 100 % / —	—
	93	PID action set point for PU operation	0 – 100 %	0 %
	94	PID differential time	0.01 – 10 s / —	—
	Slip compensation	95	Rated motor slip	0 – 50 % / —
96		Slip compensation time constant	0.01 – 10 s	0.5 s
97		Output region for slip compensation	0 / —	—
Autom. torque boost	98	Automatic torque boost (motor capacity)	0.2–3.7 kW (FR-S 520), 0.4–3.7 kW (FR-S 540) / —	—
	99	Motor primary resistance constant A	0 – 50 Ω / —	—



Pr.01



PARAMETER

Function	Parameter	Meaning	Setting range	Default setting
Calibration functions	C1 (901) ^③	AM terminal calibration	Calibration range	—
	C2 (902) ^③	Frequency setting voltage bias frequency	0 – 60 Hz	0 Hz
	C3 (902) ^③	Frequency setting voltage bias	0 – 300 %	0 % ^②
	C4 (903) ^③	Frequency setting voltage gain	0 – 300 %	96 % ^②
	C5 (904) ^③	Frequency setting current bias frequency	0 – 60 Hz	0 Hz
	C6 (904) ^③	Frequency setting current bias	0 – 300 %	20 % ^②
	C7 (905) ^③	Frequency setting current gain	0 – 300 %	100 % ^②
	C8 (269) ^③	Parameter set by manufacturer: Do not set!	—	—
Clear functions	CLr	Clear parameter	0 / 1 / 10	0
	ECL	Clear alarm history ^①	0 / 1	0
Communication functions	n1 (331) ^③	Station number	0 – 31	0
	n2 (332) ^③	Communication speed	48 / 96 / 192	192
	n3 (333) ^③	Stop bit length / data length	0 / 1 data length 8 10 / 11 data length 7	1
	n4 (334) ^③	Parity check	0 / 1 / 2	2
	n5 (335) ^③	Number of communication retries	0 – 10 / —	1
	n6 (336) ^③	Communication check time interval	0 – 999 s / —	—
	n7 (337) ^③	Wait time setting	0 – 150 ms / —	—
	n8 (338) ^③	Operation command write	0 / 1	0
	n9 (339) ^③	Speed command write	0 / 1	0
	n10 (340) ^③	Link start mode selection	0 / 1	0
	n11 (341) ^③	CR / LF selection	0 / 1 / 2	1
	n12 (342) ^③	E ² PROM selection	0 / 1	0
	n13 (145) ^③	PU display language	0–7	1
	n14 (990) ^③	PU buzzer sound control ^①	0 / 1	1
	n15 (991) ^③	PU contrast adjustment ^①	0 – 63	58
	n16 (992) ^③	PU main display screen data selection ^①	0 / 100	0
	n17 (993) ^③	PU disconnection detection / PU setting lock	0 / 1 / 10	0

Remarks:

- ① The settings of the parameters can be changed during operation, provided parameter 77 is set to "0". Parameters 53, 70, and 72 can only be changed during PU operation.
- ② The values depend on the settings of the calibration parameters.
- ③ The parameter numbers in brackets are displayed by the parameter unit FR-PU04.

Overview of protective functions

The inverters FR-S 500 EC/ECR provide a large number of protective functions that protect the drive and the inverter against damage in case of any malfunction.

If an error occurs, the output of the inverter is suspended and the control panel returns an error message.



Display	Meaning	Description	Remedy
OC1	Overcurrent 1 (acceleration)	A) The output current of the inverter has reached or exceeded 200 % of the rated current during acceleration, deceleration, or at constant speed. B) The temperature of the main circuits of the inverter rises rapidly.	The cause for the activation of the protective function is a short circuit or a ground fault across the main outputs, an exceeding moment of inertia of the load (GD ²), too short acceleration / deceleration time presets, restart during a motor idling phase, operation of a motor with an exceeding capacity. Overheating due to insufficient cooling (defective cooling fan or choked heat sink).
OC2	Overcurrent 2 (constant speed)		
OC3	Overcurrent 3 (deceleration)		
OV1	Overvoltage 1 (acceleration)	The converter voltage has increased highly due to regenerative energy. The overvoltage limit was exceeded during acceleration, deceleration, or at constant speed.	In most cases the protective function is activated due to a too short deceleration time preset or a regenerative overload. Increase the deceleration time by connecting an external brake unit. An overvoltage in the mains power supply activates this protective function as well.
OV2	Overvoltage 2 (constant speed)		
OV3	Overvoltage 3 (deceleration)		
THN	Overload (motor)	The electronic overload protection for the motor or inverter was activated.	Decrease the motor load to avoid an activation. Check whether the performance range of the motor and inverter correspond.
THT	Overload (inverter)	The electronic motor protection switch continually detects the motor current and the output frequency of the inverter. If a self-cooling motor operates over a long period at low speed but high torque, the motor is thermally overloaded and the protective function is activated. If several motors are operated by one inverter the motor protection switch will not operate properly. In this case deactivate the motor protection and replace it by external protection switches.	
FIn	Fin overheat	If the cooling fin overheats, the fin overheat sensor activates and halts inverter output.	Check ambient temperature.
Fn	Fan breakdown	The cooling fan breaks down or an operation different from the setting of parameter 76 is performed.	Replace cooling fan. Check Parameter 76.
GF	Ground fault	An overcurrent occurred due to a ground fault upon the inverter output (load side).	Check load connections (motor circuit).
OHT	Activation of an external motor protection relay (thermal contact)	An external motor protective switch was activated. If an external motor protective switch for thermal monitoring is used, this switch can activate the protective function of the inverter.	Check motor load and drive.
OLT	Stall prevention overload	A long lasting excess of the current limit (OL display) shuts down the inverter.	Reduce the load. Check the preset values for the current limit (parameter 22) and the stall prevention selection (parameter 21).
OPT	Communication error	The protective function is activated, if a setting or connection error occurs during serial communication.	Check connections and connectors of the optional unit.
PE	Memory error	Error on access of the data memory of the inverter.	Please contact your nearest MITSUBISHI ELECTRIC representative if the error occurs again.
PUE	Parameter unit connection error	A connection error between inverter and external parameter unit occurred during operation. This alarm is only returned, if parameter 17 is set to "1".	Check the connection of the parameter unit.
rET	Automatic restart retry exceeded	After activation of a protective function the inverter failed to be restarted automatically within the number of retries specified in parameter 67.	Remedy the actual cause of the original protective function.
CPU	CPU error	Scan time of CPU was exceeded. Failure on CPU printed circuit board.	Restart the inverter. Contact the MITSUBISHI ELECTRIC customer service if the error occurs again.
PS	Inverter was stopped via control panel or PU	STOP key on the control panel or PU was pressed during external operating mode.	Check parameter 75.
OL	Overcurrent during acceleration	If a current of more than 150 % ^① of the rated inverter current flows in the motor, this function stops the increase of the frequency until the overload current reduces to prevent the inverter from resulting in overcurrent shut-off. When the overload current has reduced below 150 %, this function increases the frequency again.	Change the acceleration/deceleration time. Increase the stall prevention operation level via parameter 22. Disable the stall prevention via parameter 21. Check whether the torque boost in parameter 0 is set higher than required.
	Overcurrent during constant speed	If a current of more than 150 % ^① of the rated inverter current flows in the motor, this function lowers the frequency until the overload current reduces to prevent the inverter from resulting in overcurrent shut-off. When the overload current has reduced below 150 %, this function increases the frequency up to the set value.	
	Overcurrent during deceleration	If a current of more than 150 % ^① of the rated inverter current flows in the motor, this function stops the decrease of the frequency until the overload current reduces to prevent the inverter from resulting in overcurrent shut-off. When the overload current has reduced below 150 %, this function decreases the frequency again.	

Display	Meaning	Description	Remedy
oL	Overvoltage during deceleration	If the regenerative energy of the motor exceeds the brake capacity of the inverter, this function stops the decrease of the frequency to prevent overvoltage shut-off. When the regenerative energy has reduced, deceleration resumes.	Increase the deceleration time via parameter 8.
Uu	Undervoltage	The power supply voltage is too low ($U_e = 115 \text{ V AC}$).	Check the power supply voltage.
Er1	Write error	Write was performed with "1" (write disable) set in parameter 77 or frequency jump setting range overlapped or parameter write was performed via the control panel although it was not write enabled.	Check the settings of parameters 77, 31 to 36, and 17.
Er2	Write error	Write was performed during operation or in the external operation mode or an attempt was made to change the operation mode set by an operation command via parameter 79.	Stop operation before changing settings. Select PU (parameter unit) operation mode.
Er3	Calibration error	Analog input bias and gain are set too closely.	Check the settings of parameters C3, C4, C6, and C7.
Err	Error (general)	Error in the internal CPU	Contact your MITSUBISHI ELECTRIC customer service.

① The current limit value (parameter 22) can be changed. By default, it is set to 150 %.

Activating a protective function and resetting methods

When a protective function is activated, the output of the inverter is switched off. The motor runs until stop. The output remains switched off until the error cause is eliminated and the inverter is reset. The inverter can be reset following four different methods:

- Switch the power supply OFF and ON again.
- Switch the reset signal ON for at least 0.1 s and switch it OFF again. (shortly connect the terminals RES and SD (sink logic) or RES and PC (source logic))
- Press the RESET key on the integrated control panel.
- Menu-guided reset via the optional parameter unit FR-PU04

If the reset signal is ON continuously, the integrated control panel returns an error message while the control unit FR-PU04 indicates that the reset procedure is in progress.

When a protective function is activated, the control panel returns an error code as listed in the table above.

The parameter unit FR-PU04 returns a more detailed error message.

If an error occurs and the input protection contactor is triggered, the error message cannot be retained, since there is no power supply for the control circuit.

Menu-guided reset via FR-PU04

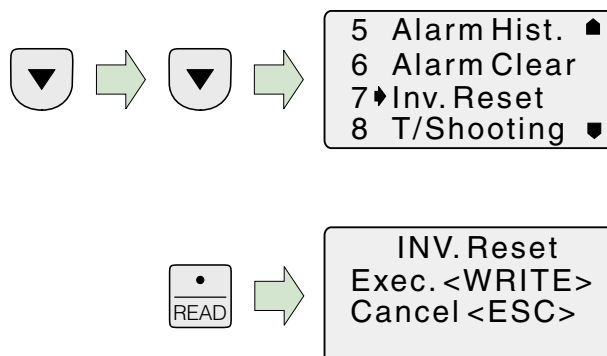

Sample Applications

Automatic operation using DC (0/4–20 mA) current signals

The figure on the right shows the layout of a circuit for automatic operation when used in combination with controllers such as temperature control for air-conditioners.

It can be switched from inverter operation to commercial power supply operation and vice versa. To switch from commercial power supply operation to inverter operation, the motor has to be stopped first.

Operation automatically switches to commercial power supply operation when an alarm stop occurs in the inverter.

Assign the AU signal to the RM terminal to switch between a 4 to 20 mA signal from the controller and a manual signal (voltage) from the speed setter.

Parameter 75 should be set so that the reset input signal can be changed to an error reset only when an inverter alarm has been stopped.

Related parameters:

Pr. 75 "Reset selection", Pr. 60 to Pr. 63 "Input terminal function selection"

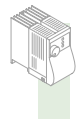
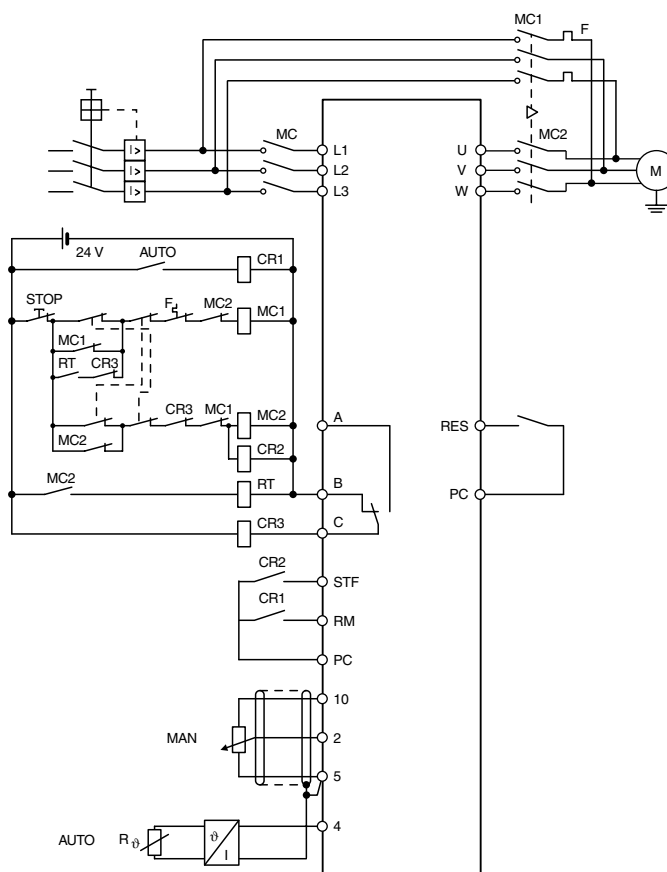

Pr. 01

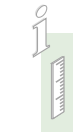

Multi-speed operation (with Mitsubishi PLC)

The figure on the right shows the layout of a sample circuit for multi-speed operation with a Mitsubishi PLC. The PLC is equipped with a digital output module AY80.

To prevent wrap-arounds, the output modules common pin 10 for preventing wrap-arounds must be connected to inverter terminal SD.

A variety of functions for the inverters transistor input signals (RH, RM, STOP etc.) are selectable using parameter 60 to 63. These inverter output signals (RUN, ABC), however, can be received at a separate digital input module.

Up to 15 speeds can be set with the multi-speed setter, and by shorting terminals 10 and 2 for an upper limit frequency setting (Pr. 1) and terminals 2 and 5 for a lower limit frequency setting (Pr. 2) 17 speeds can be obtained.

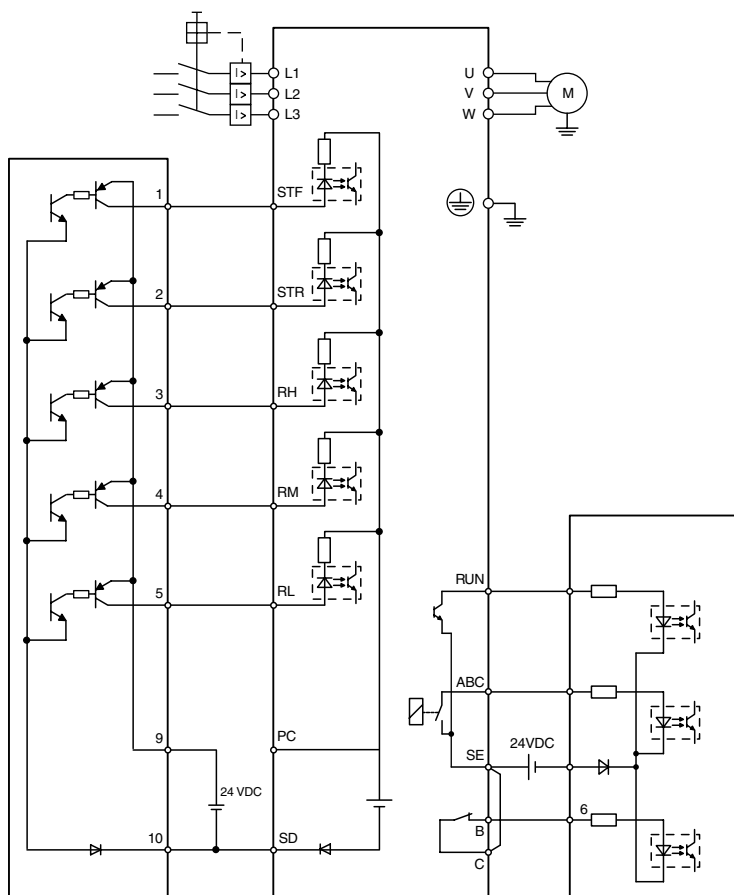

Options

External options

Besides the parameter unit FR-PU04 that provides an interactive control of the inverter the external options include noise

filters complying with the EMC directives, filters improving the efficiency as well as brake units and brake resistors.

Option	Type	Description	Remarks / specifications	Art. no.	
Parameter unit (8 languages)	FR-PU04	Interactive parameter unit with LC display	For details refer to p.13.	67735	
Connection cable for the parameter unit	FR-AS CBL	Cable for a remote connection of the parameter unit FR-PU04.	Available length: 1; 2.5 and 5 m	1 m: 70727 2.5 m: 70728 5 m: 70729	
Interface cable	SC-FR PC	Communications cable for RS232 or RS485 interface to connect an external personal computer	Length 3 m; can be used for example with the VFD Setup Software (only with ECR version)	88426	
VFD Setup Software	FR-SW0-SETUP-W□	Parameter and setup software for the FR-S 500, FR-E 500, FR-F500 and FR-A 500 series inverters	English / German	149718	
External options EMC noise filter	FR-S 520S-0.2 – 0.75k EC/ECR	FR-S5NFS A-0.75 k, FR-S5NFS B-0.75 k, FFR-S520S-14A-RF1	Noise filter for the FR-S 520 series for compliance with EMC directives	For details refer to p. 21	see p. 21
	FR-S 520S-1.5k EC/ECR	FR-S5NFS A-1.5 k, FR-S5NFS B-1.5 k, FFR-S520S-20A-RF1			
	FR-S 540-0.4 – 1.5 k EC/ECR	FFR-S540-8A-RF100	Noise filter for the FR-S 540 series for compliance with EMC directives	For details refer to p. 21	138425
	FR-S 540-2.2 – 3.7 k EC/ECR	FFR-S540-13A-RF100			138423
Brake unit	FR-S 520 S EC/ECR	BU-UFS-22J	For improving the brake capacity. For loads with high moment of inertia or negative loads. Used in combination with a resistor unit.	For details refer to p. 21	127962
	FR-S 540 EC/ECR	BU-UFS-22			127947
DIN rail mounting set		FR-UDA 01	Adapter for mounting frequency inverters up to 0.75 k on a DIN rail	When using the DIN rail adapter, filters can not be footprint mounted	130833
		FR-UDA 02	Adapter for mounting frequency inverters from 1.5 k on a DIN rail		130832

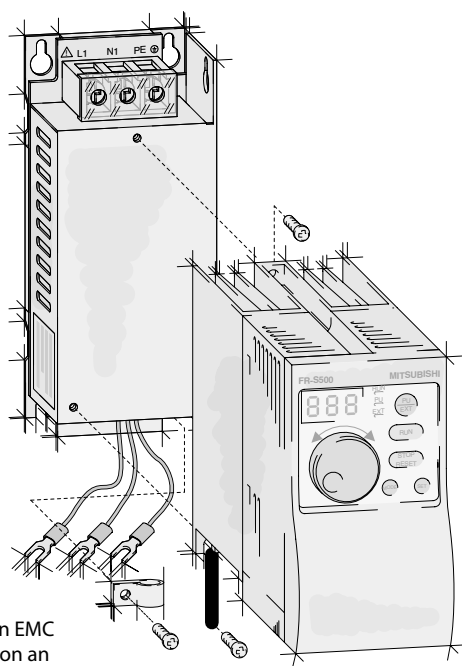

Installing an EMC noise filter on an FR-S 520 EC

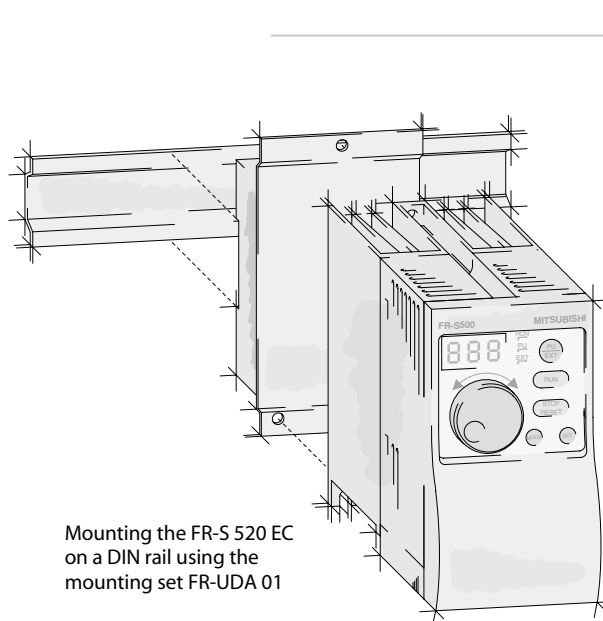

Mounting the FR-S 520 EC on a DIN rail using the mounting set FR-UDA 01

■ Noise Filters

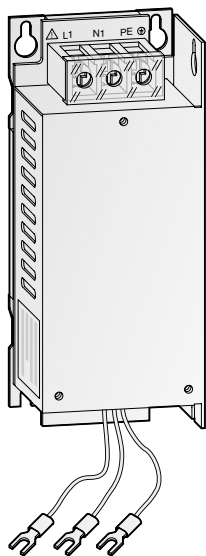

Noise filters

For complying with the EMC directives of the European Community regarding the electromagnetic compatibility, the FR-S 500 inverter has to be equipped with a noise filter across the input circuit. Additionally it has to be installed and wired according to the EMC directives.

To ensure a proper and safe operation of the components follow the points below:

- For the selection of a ground fault protective switch or relay take the leakage current of the filter into account.
- Ensure a perfect grounding of the filter, if you do not intend to use a protective switch or relay across the input circuit.

Filter	Inverter	Power loss [W]	Rated current [A]	Leakage current [mA]	Weight [kg]	Art no.
FR-S 5NFSA-0.75 k ^①	FR-S 520S-0.2 k – 0.75 k EC/ECR	1.74	14	< 4.5	0.7	129356
FR-S 5NFSA-1.5 k ^①	FR-S 520S-1.5 k EC/ECR	8.55	25	< 9.5	0.8	129357
FR-S 5NFSB-0.75 k ^③	FR-S 520S-0.2 k – 0.75 k EC/ECR	6.75	14	< 9.5	0.9	129358
FR-S 5NFSB-1.5 k ^③	FR-S 520S-1.5 k EC/ECR	9.25	20	< 14	1.3	129359
FFR-S520S-14A-RF1 ^②	FR-S 520S-0.2 k – 0.75 k EC/ECR	6.5	14	< 7	0.8	152736
FFR-S520S-20A-RF1 ^③	FR-S 520S-1.5 k EC/ECR	12	20	< 10	1.0	152740
FFR-S540-8A-RF100 ^④	FR-S 540-0.4 – 1.5 k EC/ECR	5.1	8	< 10	0.8	138425
FFR-S540-13A-RF100 ^④	FR-S 540-2.2 – 3.7 k EC/ECR	7.1	13	< 10	0.9	138423

① All filters conform to EN55011A at a cable length of 5 m and EN55022B at 1 m.
 ② All filters conform to EN55011A at a cable length of 75 m and EN55022B at 30 m.
 ③ All filters conform to EN55011A at a cable length of 100 m and EN55022B at 30 m.
 ④ All filters conform to EN55011A at a cable length of 100 m and EN55022B at 20 m.

■ Brake Units

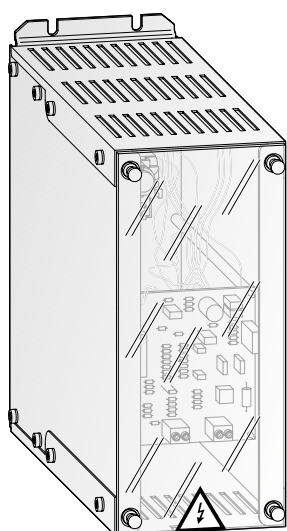

Brake units

If an application demands a braking torque higher than 20 % of the nominal motor torque, an external brake unit including the appropriate resistors has to be installed.

The brake units BU-UFS listed below are cascable and therefore always providing the optimum adjustment.

For informations on the dimensioning of the appropriate brake resistors please refer to the appropriate brake unit manual.

Inverter	Brake unit	Application	Rated voltage	Braking torque	Art no.
FR-S 520 S EC/ECR	BU-UFS22J	FR-S 520-0.2 – 1.5 k	200 V	100 %, 15 s	127962
FR-S540 EC/ECR	BU-UFS22	FR-S 540-0.4 – 3.7 k	400 V	100 %, 15 s	127947

DIMENSIONS

Parameter Unit FR-PU04

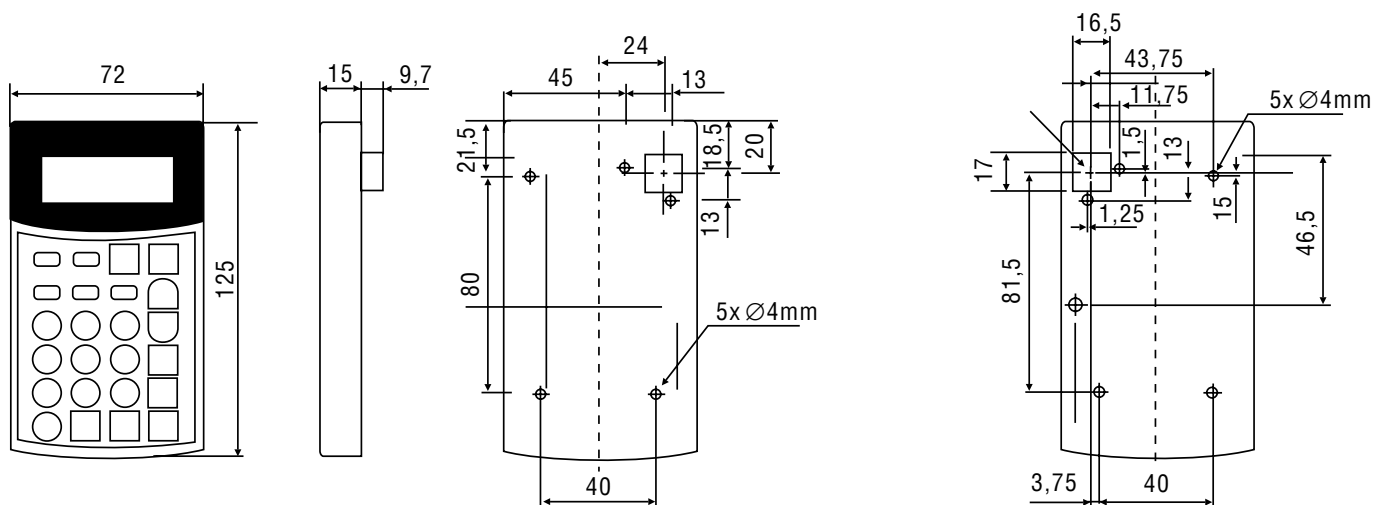

All dimensions in mm

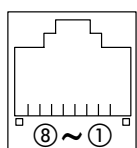

- | | |
|-------|-------|
| ① SG | ⑤ SDA |
| ② P5S | ⑥ RDB |
| ③ RDA | ⑦ SG |
| ④ SDB | ⑧ P5S |

Connecting the parameter unit

After the protective cover has been removed, the parameter unit can be installed directly on the inverter. The parameter unit can be connected to the inverter remotely via the connecting cable FR-A5-CBL (1m; 2.5m; 5m). You must use only the original MITSUBISHI ELECTRIC cable. This cable is optionally available.

Plug the cable in the according connectors on the parameter unit and the inverter.

The figure aside shows the pin assignment of the connector plugs.

Do not connect fax modems, LAN network boards, or modular telephone plugs with the connectors. Otherwise, the inverter might be damaged.

The connector for the parameter unit can as well be used to connect a personal computer via the communications cable SC-FR PC.

FR-S 520 S-0.2 k to 0.75 k EC/ECR

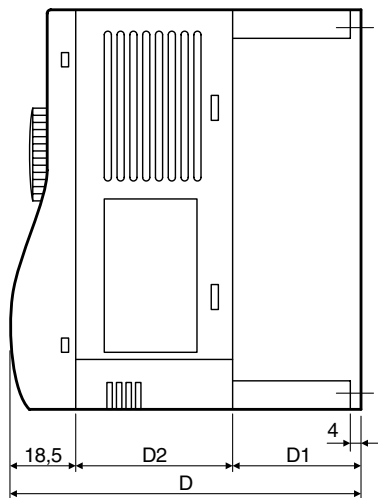
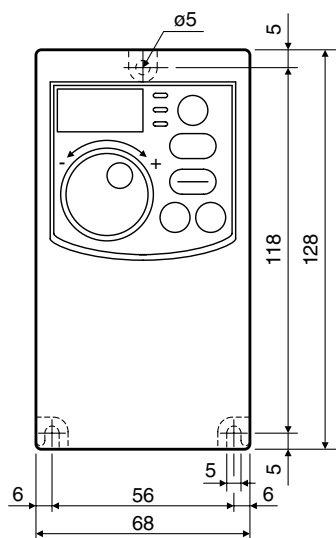

Type	D	D1	D2
FR-S 520 S-0.2 k	80.5	10	52
FR-S 520 S-0.4 k	142.5	42	82
FR-S 520 S 0.75 k	162.5	62	82

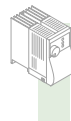

All dimensions in mm



FR-S 520 S-1.5 k EC/ECR and FR-S 540-0.4 k to 3.7 k EC/ECR

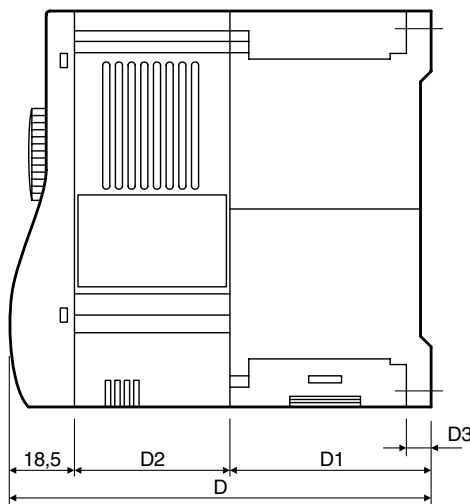
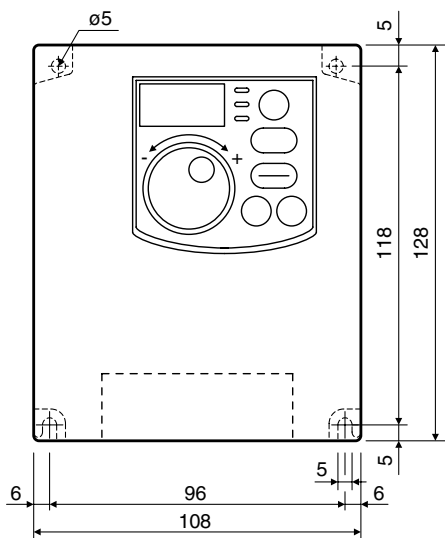

All dimensions in mm

Type	D	D1	D2	D3
FR-S 520 S 1.5 k	155.5	65	72	8
FR-S 540 0.4 k	129.5	59	52	5
FR-S 540 0.75 k	129.5	59	52	5
FR-S 540 1.5 k	135.5	65	52	8
FR-S 540 2-2 k	155.5	65	72	8
FR-S 540 3-7 k	165.5	65	82	8



DIMENSIONS

■ Noise Filters FR-S5NFSA/B-0.75 k, FR-S5NFSA/B-1.5 k and FFR-S520S-14A/20A-RF1

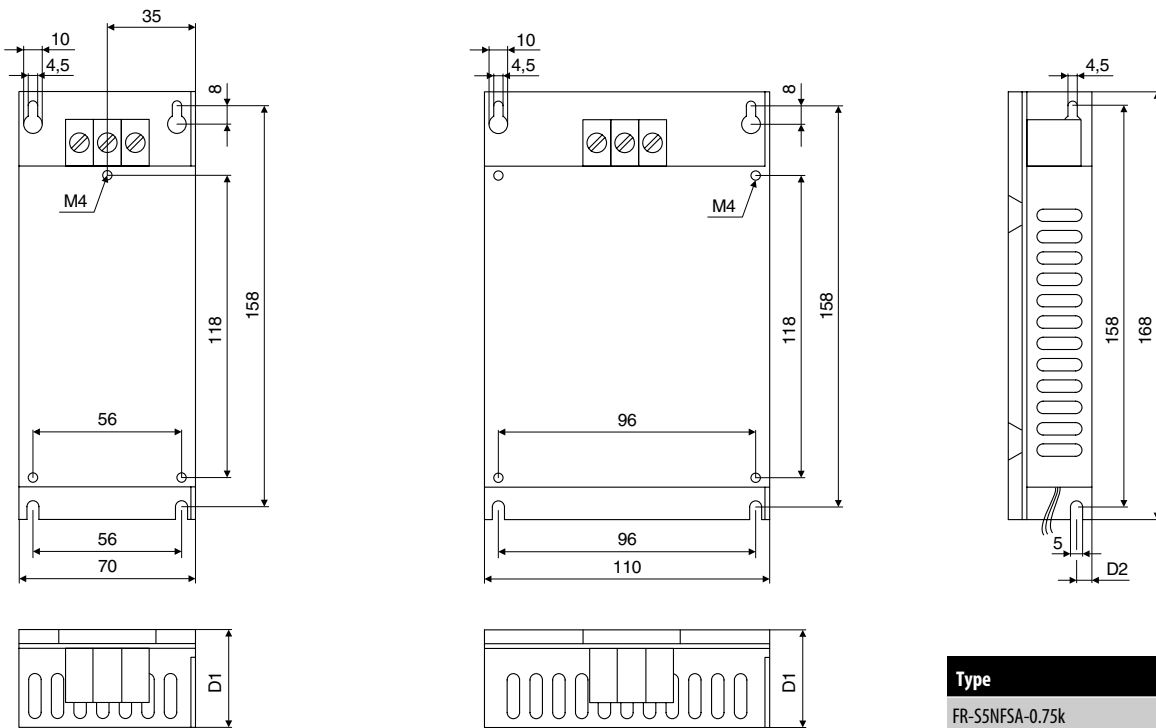

Type	D1	D2
FR-S5NFSA-0.75k	35	9,5
FR-S5NFSA-1.5k	35	9,5
FR-S5NFSA/B-0.75k	47	11
FR-S5NFSA/B-1.5k	47	11
FFR-S520S-14A-RF1	38	19
FFR-S520S-20A-RF1	38	19

All dimensions in mm

■ Noise Filters FFR-S540-8A-RF100 and FFR-S540-13A-RF100

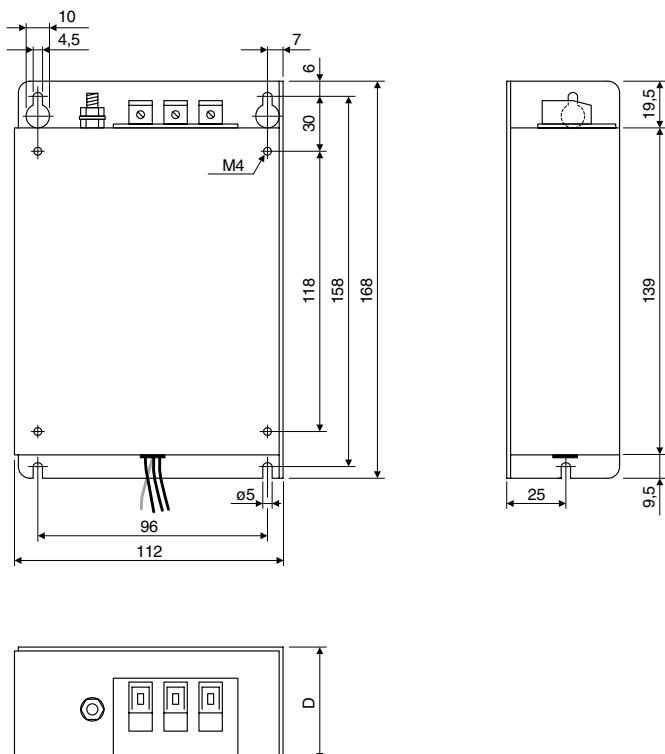

Type	D
FFR-S540-8A-RF100	40
FFR-S540-13A-RF100	45

All dimensions in mm

■ Brake Unit BU-UFS22J and BU-UFS22

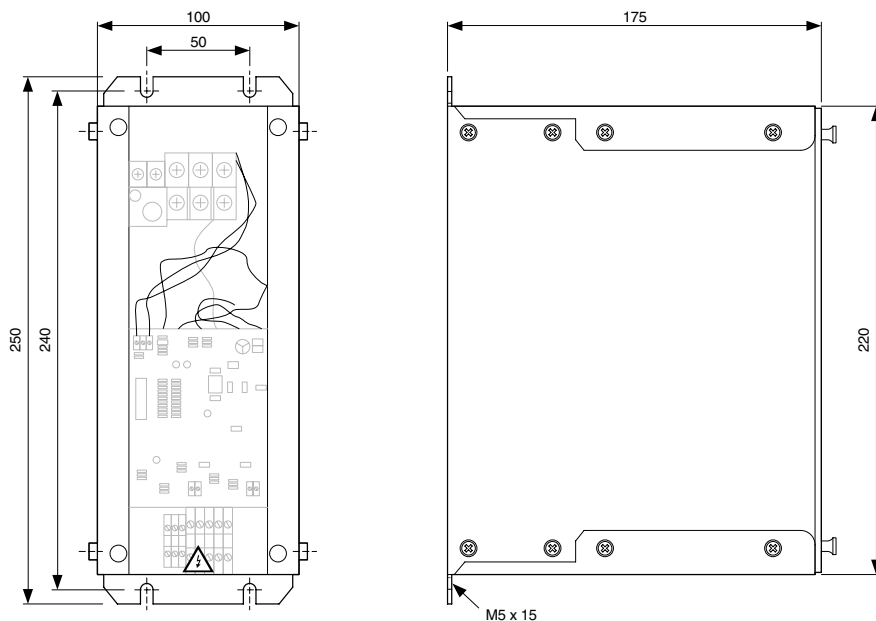

All dimensions in mm

■ DIN Rail Mounting Set FR-UDA

FR-UDA01

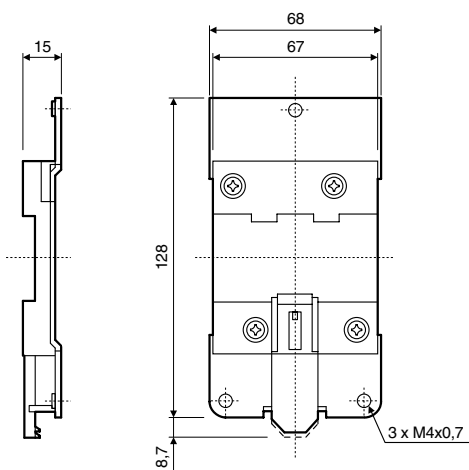

FR-UDA02

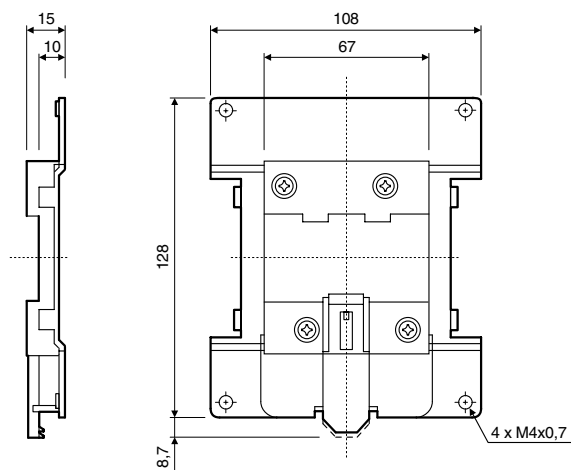

All dimensions in mm

ORDER FORM

<p>MITSUBISHI ELECTRIC EUROPE B.V. Industrial Automation / German Branch Gothaer-Str. 8 D-40880 Ratingen</p> <p>Fax: +49 2102 486-7170</p>	<p>Company:</p> <p>Department:</p> <p>Street:</p> <p>Address:</p> <p>Phone:</p> <p>Fax:</p>
--	---

Order declaration

Pos.	Number	Item (type)	Article number	Description	Remarks

Notes when ordering:
 When ordering, please use only the type designations and order numbers shown in this catalogue.

A		M	
Ambient conditions	9	Maintenance	5
B		Menu guide	
Block diagram	10	Integrated control panel.	6
C		Optional parameter unit FR-PU04	12
Communication capabilities.	4	N	
Control unit		Noise filters	
Dimensions	22	Dimensions	24
Integrated control panel	12	Description	21
Optional parameter unit FR-PU04	12	O	
D		Operating modes.	13
Dimensions		Operating conditions	9
Brake unit	25	Order form	26
DIN Rail Mounting Set.	25	Operation	6
Frequency inverter.	23	Options	20
Noise filters	24	P	
Parameter unit FR-PU04	22	Parameters.	14
E		Power supply connection	10
Error indication	17	Protective functions	17
EMC compatibility	7	R	
External options	20	RESET function	18
F		Reset methods after error	18
FR-PU04	12	S	
Frequency inverter		Sample applications	19
Dimensions	23	Signal terminals.	11
Specifications.	8	Soft-PWM function	7
Functional range.	4	Specifications	
Functional overview		Brake unit	21
Inverter.	8	Frequency inverter	8
Parameters.	14	Noise filter	21
H		System description	4
Handling		T	
Control panel	12	Terminal assignment	
Frequency inverter	6	Frequency inverter.	10
		Operating items	13, 22
		Torque characteristics	4

HEADQUARTERS

MITSUBISHI ELECTRIC EUROPE B.V. **EUROPE**
 German Branch
 Gothaer Straße 8
D-40880 Ratingen
 Phone: +49 (0) 21 02 / 486-0
 Fax: +49 (0) 21 02 / 4 86-11 20
 e mail: megfamail@meg.mee.com

MITSUBISHI ELECTRIC EUROPE B.V. **FRANCE**
 French Branch
 25, Boulevard des Bouvets
F-92741 Nanterre Cedex
 Phone: +33 1 55 68 55 68
 Fax: +33 1 55 68 56 85
 e mail: factoryautomation@fra.mee.com

MITSUBISHI ELECTRIC EUROPE B.V. **ITALY**
 Italian Branch
 Via Paracelso 12
I-20041 Agrate Brianza (MI)
 Phone: +39 039 / 60 53 1
 Fax: +39 039 / 60 53 312
 e mail: factoryautomation@it.mee.com

MITSUBISHI ELECTRIC EUROPE B.V. **SPAIN**
 Spanish Branch
 Carretera de Rubí 76-80
E-08190 Sant Cugat del Vallés
 Phone: +34 9 3 / 565 3131
 Fax: +34 9 3 / 589 2948
 e mail: industrial@sp.mee.com

MITSUBISHI ELECTRIC EUROPE B.V. **UK**
 UK Branch
 Travellers Lane
GB-Hatfield Herts. AL10 8 XB
 Phone: +44 (0) 1707 / 27 61 00
 Fax: +44 (0) 1707 / 27 86 95

MITSUBISHI ELECTRIC CORPORATION **JAPAN**
 Office Tower "Z" 14 F
 8-12,1 chome, Harami Chuo-Ku
Tokyo 104-6212
 Phone: +81 3 / 622 160 60
 Fax: +81 3 / 622 160 75

MITSUBISHI ELECTRIC AUTOMATION **USA**
 500 Corporate Woods Parkway
Vernon Hills, IL 60061
 Phone: +1 847 / 478 21 00
 Fax: +1 847 / 478 22 83

EUROPEAN REPRESENTATIVES

GEVA **AUSTRIA**
 Wiener Straße 89
A-2500 Baden
 Phone: +43 (0)2252 / 85 55 20
 Fax: +43 (0)2252 / 488 60
 e mail: office@geva.at

TEHNIKON **BELARUS**
 Oktjabrskaya 16/5, Ap 704
BY-220030 Minsk
 Phone: +375 (0)17 / 2104626
 Fax: +375 (0)17 / 2275830
 e mail: tehnikon@belsonet.net

Getronics b.v. **BELGIUM**
 Control Systems
 Pontbeeklaan 43
B-1731 Asse-Zellik
 Phone: +32 (0)2 / 467 17 51
 Fax: +32 (0)2 / 467 17 45
 e mail: infoautomation@getronics.com

TELECON CO. **BULGARIA**
 4, A. Ljapchev Blvd.
BG-1756 Sofia
 Phone: +359 (0)2 / 97 44 058
 Fax: +359 (0)2 / 97 44 061
 e mail: —

INEA CR d.o.o. **CROATIA**
 Drvinje 63
HR-10000 Zagreb
 Phone: +385 (0)1 / 3667140
 Fax: +385 (0)1 / 3667140
 e mail: —

AutoCont **CZECH REPUBLIC**
 Control Systems s.r.o.
 Nemocnicni 12
CZ-70200 Ostrava 2
 Phone: +420 59 / 6152 111
 Fax: +420 59 / 6152 562
 e mail: consys@autocont.cz

Louis poulsen **DENMARK**
 industri & automation
 Geminivej 32
DK-2670 Greve
 Phone: +45 (0)43 / 95 95 95
 Fax: +45 (0)43 / 95 95 91
 e mail: lpia@lpmail.com

UTU Elektrotehnika AS **ESTONIA**
 Pärnu mnt.160i
EE-10621 Tallinn
 Phone: +372 6 / 51 72 80
 Fax: +372 6 / 51 72 88
 e mail: utu@utu.ee

UTU POWEL OY **FINLAND**
 Box 236
FIN-28101 Pori
 Phone: +358 (0)2 / 550 800
 Fax: +358 (0)2 / 550 8841
 e mail: tehoelektroniikka@urhotuominen.fi

UTECO A.B.E.E. **GREECE**
 5, Mavrogenous Str.
GR-18542 Piraeus
 Phone: +302 (0)10 / 42 10 050
 Fax: +302 (0)10 / 42 12 033
 e mail: uteco@uteco.gr

Meltrade Automatika Kft. **HUNGARY**
 55, Harmat St.
HU-1105 Budapest
 Phone: +36 (0)1 / 2605 602
 Fax: +36 (0)1 / 2605 602
 e mail: office@meltrade.hu

SIA POWEL **LATVIA**
 Lienes iela 28
LV-1009 Riga
 Phone: +371 784 2280
 Fax: +371 784 2281
 e mail: utu@utu.lv

EUROPEAN REPRESENTATIVES

UAB UTU POWEL **LITHUANIA**
 Savanoriu Pr. 187
LT-2053 Vilnius
 Phone: +370 (0)52323-101
 Fax: +370 (0)52322-980
 e mail: powel@utu.lt

Intehsis Srl **MOLDOVA**
 Cuza-Voda 36/1-81
MD-2061 Chisinau
 Phone: +373 (0)2 / 562 263
 Fax: +373 (0)2 / 562 263
 e mail: intehsis@mdl.net

Getronics b.v. **NETHERLANDS**
 Control Systems
 Donauweg 2 B
NL-1043 AJ Amsterdam
 Phone: +31 (0)20 / 587 6700
 Fax: +31 (0)20 / 587 6839
 e mail: info.gia@getronics.com

Motion Control **NETHERLANDS**
 Automation b.v.
 Markenweg 5
NL-7051 HS Varsseveld
 Phone: +31 (0)315 / 257 260
 Fax: +31 (0)315 / 257 269
 e mail: —

Beijer Electronics AS **NORWAY**
 Teglverksveien 1
N-3002 Drammen
 Phone: +47 (0)32 / 24 30 00
 Fax: +47 (0)32 / 84 85 77
 e mail: info@beijer.no

MPL Technology Sp. z o.o. **POLAND**
 ul. Sliczna 36
PL-31-444 Kraków
 Phone: +48 (0)12 / 632 28 85
 Fax: +48 (0)12 / 632 47 82
 e mail: krakow@mpl.pl

Sirius Trading & Services srl **ROMANIA**
 Str. Biharia Nr. 67-77
RO-013981 Bucuresti 1
 Phone: +40 (0) 21 / 201 1146
 Fax: +40 (0) 21 / 201 1148
 e mail: sirius@siriustrading.ro

ACP Autocomp a.s. **SLOVAKIA**
 Chalupkova 7
SK-81109 Bratislava
 Phone: +421 (0)7 592 22 54
 Fax: +421 (0)7 592 22 48
 e mail: info@acp-autocomp.sk

INEA d.o.o. **SLOVENIA**
 Stegne 11
SI-1000 Ljubljana
 Phone: +386 (0)1 513 8100
 Fax: +386 (0)1 513 8170
 e mail: inea@inea.si

Beijer Electronics AB **SWEDEN**
 Box 426
S-20124 Malmö
 Phone: +46 (0)40 / 35 86 00
 Fax: +46 (0)40 / 35 86 02
 e mail: info@beijer.de

ECONOTEC AG **SWITZERLAND**
 Postfach 282
CH-8309 Nürensdorf
 Phone: +41 (0) 1 / 838 48 11
 Fax: +41 (0) 1 / 838 48 12
 e mail: info@econotec.ch

EUROPEAN REPRESENTATIVES

GTS **TURKEY**
 Darülaceze Cad. No. 43A KAT: 2
TR-80270 Okmeydanı-Istanbul
 Phone: +90 (0) 212 / 320 1640
 Fax: +90 (0) 212 / 320 1649
 e mail: gts@turk.net

JV-CSC Automation **UKRAINE**
 15, M. Raskovoyi St., Floor 10,
 Office 1010
U-02002 Kiev
 Phone: +380 (0) 44 / 238 83 16
 Fax: +380 (0) 44 / 238 83 17
 e mail: csc-a@csc-a.kiev.ua

EURASIAN REPRESENTATIVES

CONSYS **RUSSIA**
 Promyshlennaya St. 42
RU-198099 St Petersburg
 Phone: +7 812 / 325 36 53
 Fax: +7 812 / 325 36 53
 e mail: consys@consys.spb.ru

ELEKTROSTYLE **RUSSIA**
 ul. Garschina 11
RU-140070 Moscow Oblast
 Phone: +7 095 / 557 9756
 Fax: +7 095 / 746 8880
 e mail: mjuly@elektrostyle.ru

ELEKTROSTYLE **RUSSIA**
 Krasnij Prospekt 220-1, Office 312
RU-630049 Novosibirsk
 Phone: +7 3832 / 10 66 18
 Fax: +7 3832 / 10 66 26
 e mail: elo@elektrostyle.ru

ICOS **RUSSIA**
 Ryazanskij Prospekt, 8A, Office 100
RU-109428 Moscow
 Phone: +7 095 / 232 0207
 Fax: +7 095 / 232 0327
 e mail: mail@icos.ru

SMENA **RUSSIA**
 Polzunova 7
RU-630051 Novosibirsk
 Phone: +7 095 / 416 4321
 Fax: +7 095 / 416 4321
 e mail: smena-nsk@yandex.ru

SSMP Rosgidromontazh Ltd **RUSSIA**
 23, Lesoparkovaya Str.
RU-344041 Rostov On Don
 Phone: +7 8632 / 36 00 22
 Fax: +7 8632 / 36 00 26
 e mail: —

STC Drive Technique **RUSSIA**
 Poslannikov per., 9, str.1
RU-107005 Moscow
 Phone: +7 095 / 786 21 00
 Fax: +7 095 / 786 21 01
 e mail: info@privod.ru

MIDDLE EAST REPRESENTATIVE

SHERF Motion Techn. LTD **ISRAEL**
 Rehov Hamerkava 19
IL-58851 Holon
 Phone: +972 (0) 3 / 559 54 62
 Fax: +972 (0) 3 / 556 01 82
 e mail: —

AFRICAN REPRESENTATIVE

CBI Ltd **SOUTH AFRICA**
 Private Bag 2016
ZA-1600 Isando
 Phone: +27 (0) 11 / 928 2000
 Fax: +27 (0) 11 / 392 2354
 e mail: cbi@cbi.co.za